

Modeling of Selective Area Laser Deposition for Solid Freeform fabrication

Y. Jacquot, G. -S. Zong and H. L. Marcus

*Center for Materials Science & Engineering
The University of Texas at Austin, Austin, TX 78712*

ABSTRACT

The results of a theoretical study of the selective area laser deposition process used for Solid Freeform Fabrication (SFF) from gas phase is presented. We show how the deposition profile of carbon deposited via pyrolytic laser chemical vapor deposition using acetylene as the source gas can be computed by taking into account heat transfer, reaction, and mass transfer processes inside the reactor. The two dimensional representation of the related experimental variables are used to describe the substrate temperature, carbon deposit, and acetylene concentration in the process. The parameters describing these processes are estimated.

INTRODUCTION

Solid Freeform Fabrication by selective area laser deposition (SALD) is a new processing approach in which computer designed parts can be produced directly from the gas phase using a computer controlled rastered substrate or laser beam. All the above can be performed with no direct human intervention during the processing. The laser deposition process modeled in this paper uses the laser to heat the substrate locally to decompose the gas into the deposited material in a layer by layer pattern that will define the part. Such a pyrolytic SALD process involves heat transfer, convective and diffusive gas-phase transport, and complicated gas-phase and gas-solid kinetics as well as laser-gas and laser-solid interactions. For SFF from the gas phase, the deposition needs to be very well controlled and high deposition rates with reasonable deposit quality is desired. It is therefore necessary to have a good understanding of how process parameters affect deposition rates and uniformities. A model that provides this capability would be of great use in process control and optimization.

For this paper we have focused our initial modeling studies on pyrolytic carbon deposition from acetylene on an alumina substrate. The theoretical study exhibit three arrays which can be used to describe the process:

- The Substrate Temperature Map (STM)
- The Carbon Deposit Map (CDM)
- The Acetylene Concentration Map (ACM)

None of them, as discussed later, is independent. Since in SALD the reactions modeled are caused by a locally heated uniformly moving substrate, the laser-induced temperature rise in the substrate as a function of time and position is modeled first. Experimentally the substrate or the laser beam may be rastered. Temperature-dependent parameters are used. The resulting growth of carbon according to theoretical and experimental results is then estimated. Finally, the acetylene concentration profile is determined using mass transfer theory.

STRUCTURE OF THE SIMULATION

The structure of the simulation to analyze the thermal and mass transfer as well as the substrate condition is based on the estimation of the following variables:

- Substrate temperature profile
- Carbon deposit thickness
- Acetylene concentration profile

which are related to the STM, CDM, and ACM arrays. These arrays are sampled representation of

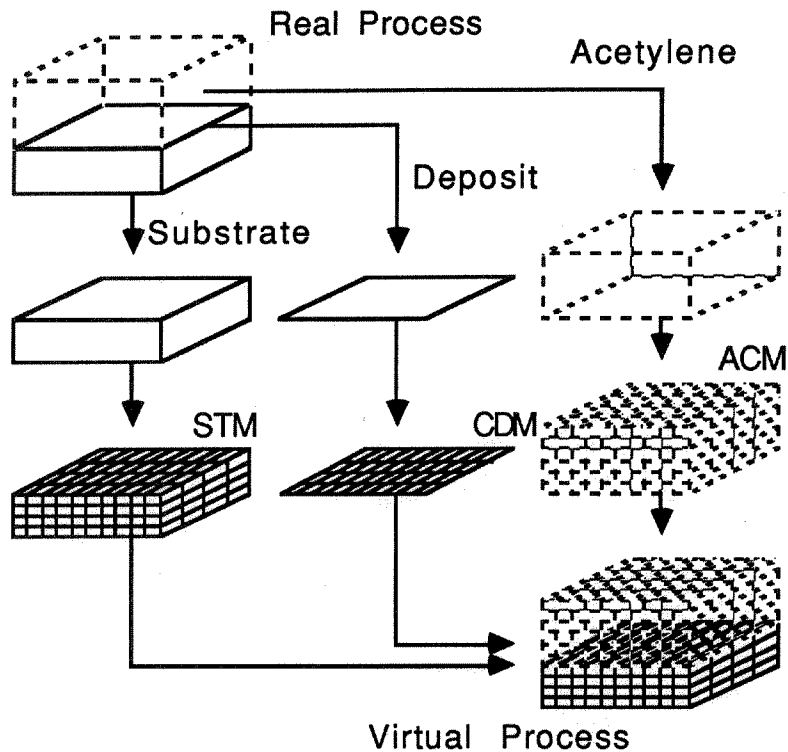

Fig. 1 Modeling of selective area laser deposition for SFF

the related experimental variables, in which heat and mass transfer laws are applied. As shown in Fig. 1, each element of the STM grid contains the local temperature T ($^{\circ}\text{K}$) at this point. Each element of the CDM display the local thickness of the carbon deposit (in μm). ACM is related to the acetylene partial pressure in Torr. The time evolution of these three arrays is given by internal

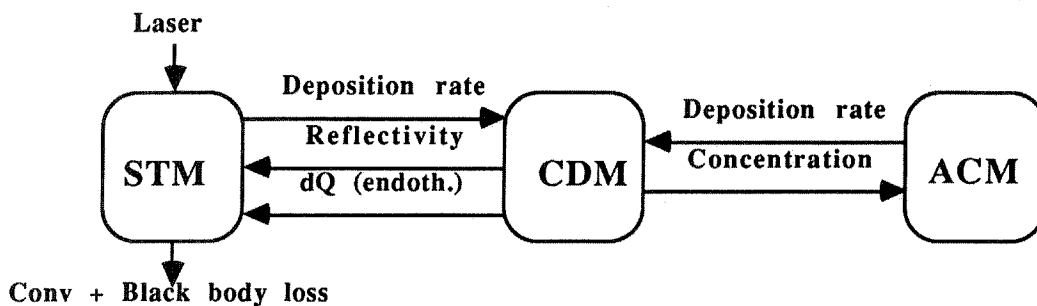

Fig. 2 Relations between STM, CDM, and ACM

evolution laws and external relations influences. The internal governing law for time-evolution is

heat transfer for STM and mass transfer for ACM. The link between all these arrays has to be considered to find out the external influences. Fig 2 displays the relations which have been taken into account in the modeling.

The laser beam heats the substrate according to the CDM (the carbon deposit decreases the reflecting power of the substrate increasing the energy absorbed). Convective and radiative losses are taken into account. The deposition occurs according to the local temperature and the gas concentration. Thus, the CDM is modified as a function of the STM and the ACM. As the chemical reaction is endothermic, the increasing of CDM affects the STM, creating a feedback ring. It also retro-affects the ACM.

In this modeling, the link between the STM and the ACM is neglected, assuming that this is taken into account in the convective loss term. We also assume that the temperature profile is not affected by the thermal conductivity of the deposit. Indeed, the deposit is localized and very thin at the early stage of the SFF. However, as the deposit thickens its heat transfer characteristics must be included.

At this point, we will discuss the modeling of STM, CDM and ACM separately.

SUBSTRATE TEMPERATURE MAP

The internal evolution of the substrate temperature profile is given by Heat Transfer Equation:
[Time evolution] [Space evolution] [Source]

$$\frac{K(T)}{D(T)} \frac{\delta T}{\delta t} - \nabla \cdot (K(T) \nabla T) = Q \quad (1)$$

where $K(T)$ is the temperature-dependent conductivity and $D(T)$ the thermal diffusivity. This equation has been solved for a scanning laser beam focused on a substrate. In general, for temperature dependent parameters, a Kirchhoff transform is applied. J.E. Moody and R.H. Hendel [1], M.L. Burgener and R.E. Reedy [2] use a Green's function method. A. Kar and J. Mazumder apply functional transformations to make a three dimensional transient thermal analysis [3]. However, all these works are only focused on thermal analysis and can not be applied to an accurate simulation of the whole process. S.D. Allen and co-works [4] study at the same time temperature evolution including changes of optical properties of the substrate due to deposition of a metal film. The resulting simulation is done for a cylindrical symmetry and a fixed laser beam. The Heat Equation is solved using a finite difference method. However, in our case, we apply the simulation to low-conductivity alumina substrate with a scanning beam such that we can not assume any cylindrical or spherical symmetry.

For our purpose, we solve the heat equation by using the Kirchhoff transform and finite difference method applied to the STM for a defined set of boundaries conditions. We show that a study of the source term of Eq (1) is useful to integrate the external relations with the CDM.

The Kirchhoff transform

$$\Theta(T) = \Theta(T_0) + \int_{T_0}^T \frac{K(T')}{K(T_0)} dT' \quad (2)$$

where Θ is the normalized temperature in $^{\circ}K$, $\Theta(T_0)$ and $K(T_0)$ are constants. Then Eq (1)

becomes

$$\frac{\delta \Theta}{\delta t} = D(T(\Theta)) \cdot [\nabla^2 (\Theta) + Q] \quad (3)$$

which can be solved by finite difference method applied on a the STM 3D grid. Assuming that we know the values of STM and boundaries conditions at time t , finite method algorithm estimate

STM at $t+dt$.

For Alumina, we have [5]:

$$K(T) = \frac{7.47}{T-96} \quad (\text{W} \cdot \text{mm}^{-1} \cdot \text{K}^{-1})$$

$$D(T) = \frac{1724}{T+140} \quad (\text{mm}^2 \cdot \text{s}^{-1})$$

where T is in $^{\circ}\text{K}$. Thus, Eq(2) becomes

$$\Theta(T) = (T_0 - 96) \cdot \ln \frac{T-96}{T_0-96}$$

$$T(\Theta) = 96 + (T_0 - 96) \cdot \exp \frac{\Theta}{T_0-96}$$

where T_0 is the reference temperature.

The boundaries conditions relative to Eq(1) and Eq(3) are given by convective and radiative heat losses through the surface described by STM. These conditions are incorporated into the source term of Eq(1). At $t = 0$, we assume

$$\text{STM}(x,y,z) = T_0$$

$$\text{CDM}(x,y) = 0$$

$$\text{ACM}(x,y,z) = \zeta_0$$

The source term Q of Eq(1) and Eq(3) is given by the amount of energy coming from the laser beam minus the convective, radiative and other losses.

The laser beam spot energy per surface distribution can be written as:

$$Q_{\text{laser}}(x,y,0) = \frac{P_{\text{laser}}}{\pi r_0^2} \cdot (1 - R(x,y)) \cdot \exp \left[-2 \cdot \frac{x^2+y^2}{r_0^2} \right] \cdot dt$$

where P_{laser} is the power of the laser (W), r_0 is the dimension of the Waist and $R(x,y)$ is the reflectivity relative to the studied point. The reflectivity is function of thickness of deposit at (x,y) (i.e. $\text{ACM}(x,y)$). We assume that

$$R(x,y) = R_c + (R_{\text{AL}_2\text{O}_3} - R_c) \exp \left[-\frac{\text{ACM}(x,y)}{d_0} \right]$$

with $R_{\text{AL}_2\text{O}_3}$ and R_c the reflecting power of alumina and carbon respectively and d_0 a characteristic distance.

The radiative/convective losses per surface are given by

$$Q_{\text{loss}}(x,y,0) = - [h \cdot (T(x,y) - T_{\text{out}}) + \sigma \cdot \epsilon \cdot (T^4(x,y) - T_{\text{out}}^4)] \cdot dt$$

where h is the convective heat transfer coefficient, σ is the Stefan-Boltzmann constant, ϵ is the hemispherical total emittance at temperature T and T_{out} is the ambient temperature. As the chemical reaction is exothermic, we also have

$$Q_{\text{chem}}(x,y,0) = K_{\text{qchem}} \cdot \Delta \text{CDM}(x,y)$$

where K_{qchem} is a constant depending on the energy of activation of the reaction and the density of carbon, and $\Delta \text{CDM}(x,y)$ is the variation of thickness of carbon deposit at (x,y) .

We have shown how to calculate $\text{STM}(x,y)$. The STM is given by solving the heat transfer

equations. Using the source term of Eq(1), we have been able to establish the desired link between STM and ACM, as planned in the above paragraph. Now, we apply the same principle to the study of the chemical reaction.

CARBON DEPOSIT MAP

CDM is a 2D grid whose elements $CDM(x,y)$ represent the local thickness of carbon deposit for the point (x,y) located at the surface of the substrate.

The set of chemical reactions involved in the carbon deposition process from acetylene is rather complex. However, we assume that the net result is given by



To find out the equation to describe the growth rate, i.e., $\Delta ACM(x,y)$, using the process parameters, both theoretical and experimental methods are considered. As in the above section, we focus this work on the relations between the growth rate and the other variables $STM(x,y)$ and $ACM(x,y)$.

For the above reaction, we have for the rate of carbon production

$$\frac{d(2C)}{dt} = K_{qchem}(T) \frac{[C_2H_2]}{[H_2]} \quad (5)$$

where K_{chem} is the temperature dependent rate constant of the reaction. According to Van't Hoff law,

$$\frac{d(\ln K_{qchem})}{dT} = - \frac{\Delta H}{RT^2}$$

R is the perfect gas constant and ΔH is the activation enthalpy of the reaction. This leads to the conclusion that the growth rate is related to the local temperature and the partial pressures of acetylene and hydrogen. We now use an experimental study to determine the applicability of the theory.

G.Leyendecker and co-workers. have determined the apparent activation energies for a reaction (5) using a chemical vapor deposition setup [6]. According to their results, the growth rate can be expressed as:

$$\frac{dl}{dt} = \exp \left[\frac{\Delta E}{k} \left(5.86 * 10^{-4} - \frac{1}{T} \right) \right] [P_{C_2H_2}]^\alpha \quad \mu m.s^{-1} \quad (6)$$

where k is the Boltzmann constant and $\alpha = \left[\frac{10^{-4} \Delta E}{\ln 10 k} \right]$. The calculation of α gives $\alpha = 1.02$. Thus we assume $\alpha \approx 1.0$. Besides, for a small area $\Delta x \Delta y$ of the chemical active surface, we can express

$$dl = \frac{M}{\rho \Delta x \Delta y} d(2C)$$

where M is the molar mass and ρ the density of carbon.

Thus we will neglect the effect of the hydrogen product in the process. The growth rate is a pure function of the STM and of the ACM thru equation (6).

We still have to study mass transfer in order to determine acetylene concentration. The principle used for it is quite similar to the one applied to heat transfer equation on STM.

ACETYLENE CONCENTRATION MAP

The Mass Transfer equation is given by:

$$\mathbf{v} \cdot \nabla c + \frac{\delta c}{\delta t} = D \cdot \nabla^2 c + R$$

With no bulk motion, $\mathbf{v} = 0$. R is the source term. In our case, R is proportional to ΔACM . We assume that the temperature of the gas is constant and equal to T_{out} . Using perfect gas equation, we find the relation between P_{C2H2} and c_{C2H2} :

$$P_{C2H2} = c_{C2H2} R \cdot T_{out}$$

As for heat transfer, this equations is solved by finite difference method on ACM.

We have now modeled STM, CDM and ACM and have evaluated the numerical formulations which describe the process. This allows us to write the algorithm

ALGORITHM

The structure of the algorithm (Fig. 3) is based on the finite difference method. Assuming that STM, CDM and ACM 2D arrays are known at t , we perform an evaluation of

$\Delta STM(t) = STM(t+dt) - STM(t)$, $\Delta CDM(t)$ and $\Delta ACM(t)$, using the equations described in the previous parts. Then we compute $STM(t+dt) = DSTM(t) + STM(t)$, $CDM(t+dt) = DCDM(t) + CDM(t)$ and $ACM(t+dt) = DACM(t) + ACM(t)$ and start again the loop with time $t+dt$.

The algorithm is very well suited for parallel calculations. Thus, the program has been developed on the Cray X-MP located at CHPC, Balcones Center, Austin, Texas, U.S.A.

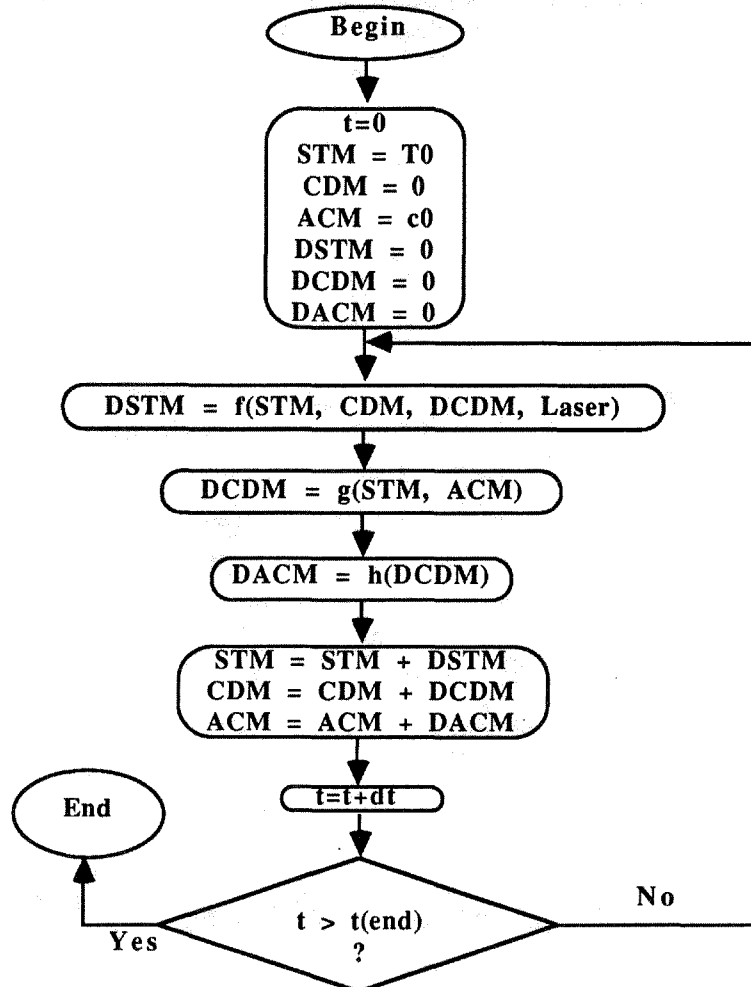

Fig. 3 The algorithm

RESULTS AND DISCUSSION

The simulation has been performed under several different conditions. The results for the following conditions are performed:

- Alumina substrate of 10 mm X 10 mm X 0.5 mm.
- Laser power of 14 W and 5 W
- Laser Waist of 250 μm .
- Laser spot scanning started from $x_0 = 4.7 \text{ mm}$ and $y_0 = 5 \text{ mm}$, moving along the y axis with a speed of 42 $\mu\text{m/s}$.
- Initial substrate temperature = 773 $^{\circ}\text{K}$

The contouring curves of Fig 4 represent carbon deposit distribution in μm at $t = 3 \text{ seconds}$. The pressure of Acetylene is initially 200 Tor.

Fig 5 shows the maximum temperature rise in $^{\circ}\text{K}$ vs time for the 1mm by 1 mm area which is directly under the laser beam for the first few seconds during scanning. The simulation was performed for two different laser powers: a). 14 W power laser on rough alumina, b). 5 W power laser on alumina with a 10 μm carbon coating. In both cases the temperature increases quickly to about 1500 $^{\circ}\text{K}$. The increased absorptivity of the 10 μm carbon coating at the lower power gives identical results with the higher power input on the alumina substrate. When the carbon is deposited on the alumina substrate the absorptivity increases and temperature instability occurs. The exothermic nature of the reaction also contributes to the temperature instability. As the result of

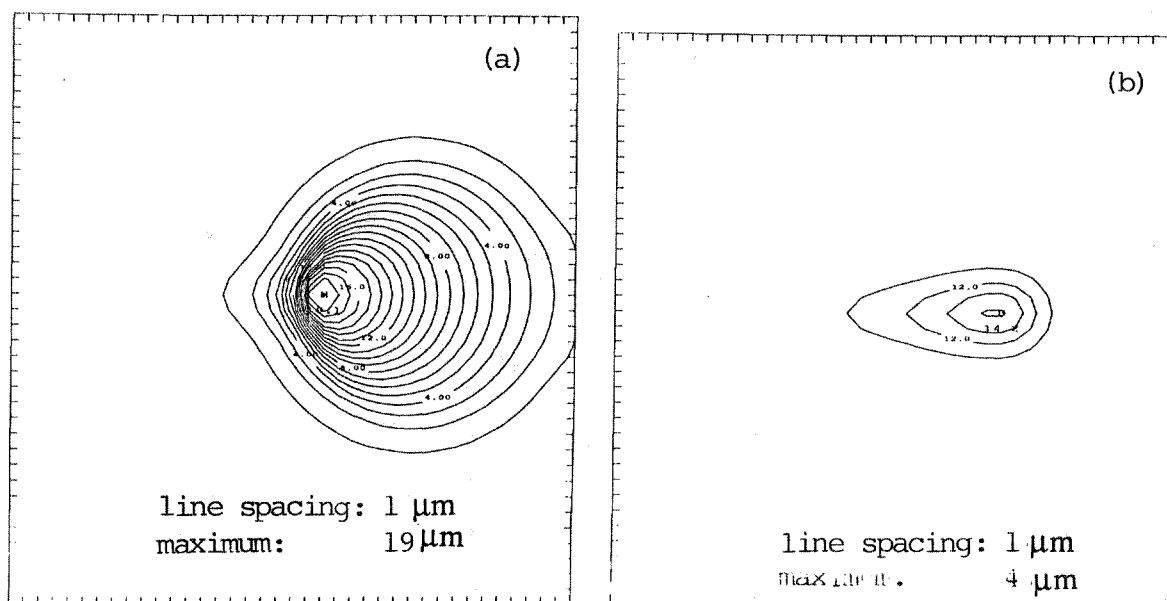

Fig. 4 Results of the carbon deposition profile simulation (in μm) for $t = 3 \text{ sec.}$. The plan represents the central 1mm X 1mm substrate area. The contouring line spacing is 1 μm . Laser scanning speed of 168 $\mu\text{m} / \text{sec.}$ a). Laser power of 14 W on rough Alumina. The maximum thickness of deposit is 19 μm . b). Laser power of 5 W on Alumina with 10 μm carbon coating. The maximum thickness of deposit is 4 μm .

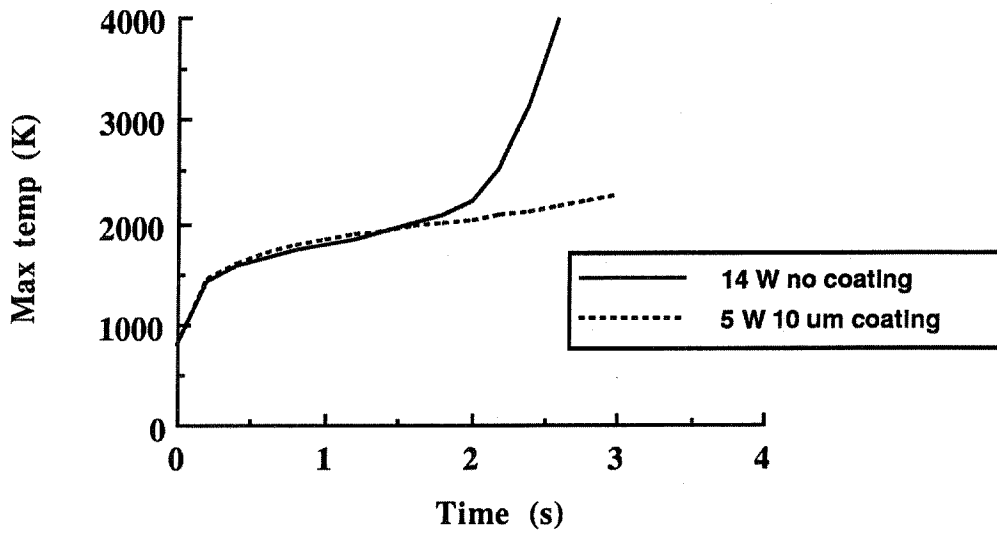

Fig. 5 Temperature profile extreme in K near the center of the sample vs time in seconds for two different setup

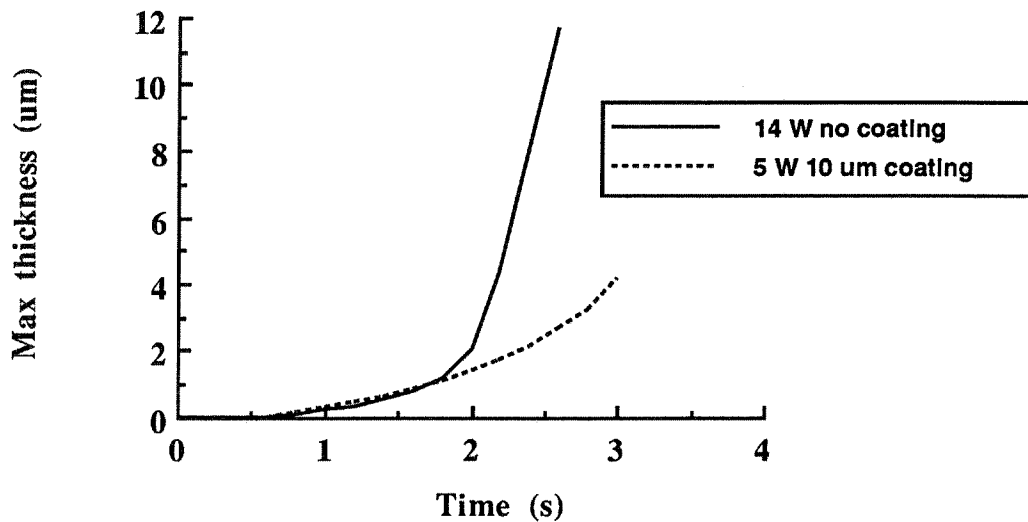

Fig. 6 Maximum thickness in μm vs time in seconds for two different laser power

these effects, the temperature increases in a kind of chain reaction process: Increasing the temperature results in higher deposition rate (Fig. 6) which increases the absorptivity and chemical energy releasing, resulting in further increasing in temperature. The increase in absorptivity will stop after about a $2 d_0$ carbon deposit (d_0 is an optical constant relative to the definition of the reflectivity $R(x,y)$ as a function of the carbon deposit thickness). This is one of the reasons for the unstable deposition process observed elsewhere[7]. A slight variation in the initial setup and substrate surface conditions, or in the sample homogeneity will result in a significant change in deposition thickness. As shown in Fig 5, the temperature goes over 3000°K . Experimentally, the

thermal condition would not be meaningful in the substrate used. The unstable problem due to the absorptivity increasing can be solved by either using the alumina plate coated with a 10 μm carbon film as a substrate to reduce the non-constant reflecting power effect, or using a thermostated heat source to control the average temperature on the substrate. The problems associated with chemical reaction energy can be solved by using an acetylene/methane gas mixture as the source gas, for the reaction is exothermic for acetylene and endothermic for methane and an appropriate combination of these two gas should assist in controlling the reaction energy production.

ACKNOWLEDGEMENTS

We wish to thank Prof. J. Stark and Mr. W. R. Thissell for valuable discussions, and V. T. Nair, J. Driver and K. Milfeld from CHPC center for their assistance in computing and data visualization. This research was supported by a Texas Advanced Research Project.

REFERENCES

- (1). J.E. Moody and R.H. Hendel, J. Appl. Phys., **53**(6), 4364 (1982).
- (2). M.L. Burgener and R.E. Reedy, J. Appl. Phys. , **53**(6), 4357 (1982).
- (3). A. Kar and J. Mazumder, J. Appl. Phys., **65**(8), 2923 (1982).
- (4). S.D. Allen, J.A. Goldstone, J. P. Stone, and R. Y. Jan, J. Appl. Phys., **59**(5), 1653 (1986).
- (5). Thermophysical Properties of Matter, Vol.10, Thermal Diffusivity, T. S. Touloukian, Editor, IFI/Plenum, New York, 378 (1973).
- (6). G. Leyendecker, H. Noll, D. Bauerle, P. Geittner and H. Lydtin, J. Electrochem. Soc.: S.S.S.&T. **130**(1), 157 (1983).
- (7). G. -S. Zong, R. Carnes, H. G. Wheat, and H. L. Marcus, Proceedings of The Solid Freeform Fabrication Symposium, Austin TX, August, 1990.