

# Automated Fabrication of Complex Molded Parts Using Mold SDM

A.G. Cooper<sup>1</sup>, S. Kang<sup>1</sup>, J.W. Kietzman<sup>1</sup>, F.B. Prinz<sup>1</sup>, J.L. Lombardi<sup>2</sup> and L. Weiss<sup>3</sup>

1. Stanford University, Stanford CA
2. Advanced Ceramics Research, Tucson AZ
3. Carnegie Mellon University, Pittsburgh PA

## ABSTRACT

Mold Shape Deposition Manufacturing (Mold SDM) is a Solid Freeform Fabrication technique for producing complex shaped fugitive wax molds. A variety of castable polymer and ceramic materials have been used to make parts from these molds. This paper describes the Mold SDM method and an automated mold building machine based on a commercial CNC mill. Process steps, material selection and equipment issues are explained. Alumina, silicon nitride, polyurethane and epoxy parts with feature sizes ranging from 0.5 to 30 mm will be shown, as well as pre-assembled mechanisms and multi-material parts.

## INTRODUCTION

Ceramic materials have excellent high temperature properties, high strength and stiffness, low density, and good chemical resistance. These properties make ceramic materials very attractive for a wide range of engineering applications. However, two principal factors currently limit the use of structural ceramics: the low toughness of ceramic materials and the difficulty of making high-quality complex shapes. The Mold SDM process addresses the latter issues.

Traditional ceramic manufacturing processes, such as machining of green ceramic blanks, work well for making simple shapes. Solid Freeform Fabrication (SFF) processes, based on layered manufacturing, can build up complex shapes but, in general, produce parts with poor surface finish, often displaying a stairstep effect on surfaces that are not vertical or horizontal. The layer boundaries are also potential sources of defects that can reduce the mechanical properties. Mold SDM was developed to address these issues. Mold SDM is a layered manufacturing process, so it can build complex shaped parts. However, it is also an additive-subtractive process which uses CNC milling to accurately shape all surfaces as they are built to minimize the stairstep effect. Although the mold is built in layers, there will be no layer boundaries in the finished part since the final part is cast monolithically.

In addition to ceramic parts, Mold SDM can be used to make parts from a variety of castable materials including polymers such as polyurethane and epoxy.

This paper describes two aspects of the Mold SDM process. First is the Mold SDM process itself in terms of process steps and the related materials and process issues. Second is the automation of the process and the construction of an automated machine that implements the mold building phase of the process.

## THE MOLD SDM METHOD

Mold SDM is a variation on Shape Deposition Manufacturing (SDM). SDM is an additive-subtractive layered manufacturing process which has been used to build a variety of metal and polymer parts [1,2]. Most SFF techniques decompose the model into relatively thin planar layers of uniform thickness. In SDM, however, the layers are three-dimensional, may be of arbitrary

thickness and do not need to be planar. This adaptive decomposition allows the number of layers to be minimized which in turn leads to reduced build times. In Mold SDM fugitive molds are built using SDM techniques and these are then used to cast a variety of part materials.

Figure 1 illustrates an example of the Mold SDM building sequence for a simple part with three layers. A mold is constructed from mold material surrounding temporary part material which defines the mold cavity. In steps 1 through 8 the mold is built up layer by layer. Removal of the temporary part material, in step 9, leaves a mold ready for casting in step 10. Once the part material has cured there are a range of processing options available. The figure shows two possible alternatives. In the first option (11a and 12a), the mold material is removed and then finishing operations, such as removal of runners and gates, are performed. In the second option (11b and 12b), the mold material is used as fixturing during finishing operations and is removed afterwards.

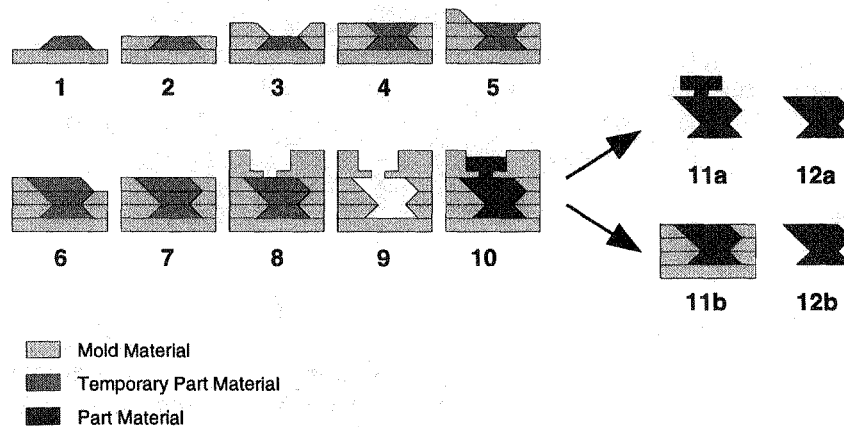

**Figure 1:** Example Mold SDM process sequence

The main advantage of Mold SDM over SDM and other layered processes is that since the final part is cast monolithically there will be no layer boundaries in the finished part. This is particularly advantageous for flaw sensitive materials, such as ceramics, or for materials with poor interlayer bonding. In comparison with direct machining of ceramic green materials, Mold SDM also minimizes the amount of part machining required which is an advantage for materials that are difficult or expensive to machine, such as ceramic green materials.

Mold SDM has several limitations over SDM. First, a third compatible material, the temporary part material, is required. The additional materials compatibility and processing requirements may restrict the range of materials that can be used. Second, there are the extra casting and mold removal steps which will increase processing time. Finally, mold filling issues may limit part geometry, although in many cases sprues and vents can be added to ensure complete mold filling.

### Materials Issues

The capability to make quality molds from which quality parts can be produced depends on a number of mold and temporary material properties [3]. The materials must have low shrinkage to reduce warping and distortion. They must bond to each other so that they do not delaminate and are able to withstand cutting forces. They must machine well so that good surfaces can be produced. They must be chemically compatible with each other so that they do not damage each other, both during the build phase and the two etching steps.

In addition to these basic requirements there are a number of other material properties which are desired to make the process more rapid or efficient. Being able to etch the temporary part

material and later the mold material quickly and easily saves time. Low cost, non-toxic materials make the process more economical.

The main issue with the mold material is the tradeoff between shrinkage and machinability. In general, machinable waxes have high shrinkage while low shrinkage waxes tend to machine poorly. Table 1 shows a range of waxes that have been tested for use in Mold SDM.

Wax	Melting Point (°C)	Shrinkage (linear %)
Kindt-Collins Master Protowax	60	0.46
Kindt-Collins Master File-a-wax	105	2.60
Freeman machinable	105	2.91
25% Kindt-Collins Master File-a-wax 75% Kindt-Collins Master Protowax	80	0.80

**Table 1:** Waxes tested for use in Mold SDM

Currently the preferred wax is the 25/75 mix of Kindt-Collins Master File-a-wax and Protowax. The File-a-wax is a machinable wax, the Protowax is a casting wax. By mixing the two it is possible to obtain a better tradeoff between machinability and shrinkage than is available in a commercially available wax.

Melting point and melt viscosity are two other important properties. A lower melting point wax is desired because this will reduce the heat input into the previous layers during wax casting thus reducing mold warpage. However, the wax must have a high enough melting point to be able to withstand the cure conditions for the final part material. Many materials require an elevated temperature cure or have an exothermic curing reaction. Low melt viscosity is beneficial since this will allow the wax to more easily fill fine features. It will also make wax removal by melting easier as the wax will run off the part more readily.

The temporary part material must be able to accurately define the mold cavity. To do this the temporary part material must be machinable so that fine features can be made and heat resistant so that it can withstand wax deposition conditions. Similar to the case for wax formulations, it was found that a better material could be obtained by mixing commercially available soldermask formulations. Mixing brittle and rubbery varieties produced a tougher, more machinable soldermask. One drawback of using this mixture, however, is that the viscosity gradually increases over time. This mixture also suffers from low heat resistance and low cure depth. Low heat resistance means that features are more likely to be distorted when hot wax is cast over the soldermask. Low cure depth reduces build rate because thick layers must be built up in several steps. The current formulation can be cured up to 1.5 mm deep in 2 minutes.

### Process Issues

In Mold SDM wax layers are deposited by mass casting. This enables much more rapid material deposition than is possible with bead extrusion systems. In order to prevent the wax from flowing away from the desired deposition area some sort of containment must be used. In Mold SDM this is done by building up thin wax walls around the deposition area. These walls are built up by extruding a higher melting point wax that has sufficient viscosity to form a narrow bead. The wax is deposited at a temperature only slightly above the melting point so that it will solidify rapidly and form precise walls. Once the walls have been formed, the lower melting point mold wax is mass cast inside the walled off areas and allowed to cool.

In order to reduce thermal stresses and minimize the potential of damage to previously built layers it is desirable to cast the wax layers at as low a temperature as possible. However at lower temperatures there will be less remelting of the previous layer, therefore the interlayer adhesion will not be as good. An option is to use preheating of the previous layer, using an IR lamp for example, to warm up the surface so that it will remelt more easily and reduce the required deposition temperatures. For example the Kindt-Collins Master File-a-wax deposition temperature can be reduced from 180°C to 160°C. One disadvantage of preheating is that interlayer discontinuities tend to be greater. This is believed to be due to softening of the surface layer that is then distorted as the new wax layer cools and shrinks above it.

The cooling time between wax deposition and machining accounts for a significant fraction of the total part build time. Wax layers must usually be allowed to cool for 2 hours for a typical 5-10 mm thick layer. Thicker layers will take longer. In order to reduce this time and increase the process rate, alternative ways of speeding the cooling of the wax are currently being investigated. By simply blowing cool air over the surface it is possible to reduce cooling times by a factor of 2-4.

## PROCESS AUTOMATION

To improve the rate of production and the quality of parts made by Mold SDM, an automated mold-making machine has been built. The machine, shown in Figure 2, is based on a commercially available Haas VF-0E 3-axis CNC milling machine. The mill was modified by the addition of material deposition and curing hardware. Ultimately one could produce either complete Mold SDM machines or retrofit kits that could be installed on existing CNC machines.

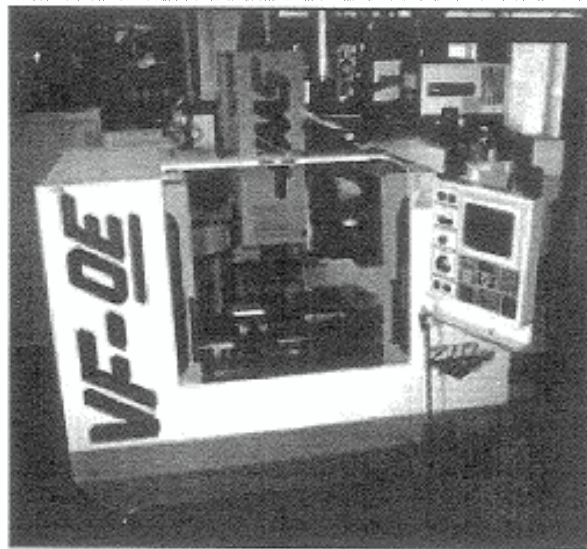
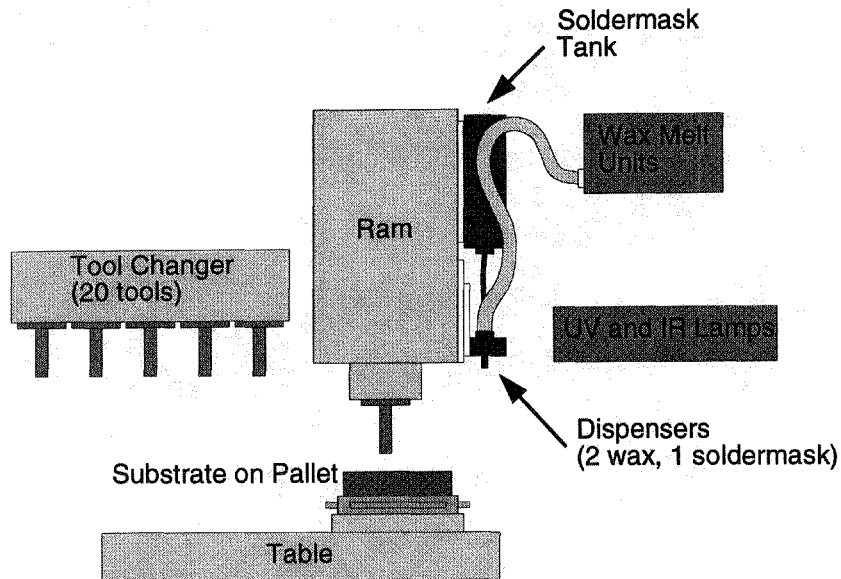

**Figure 2:** Automated Mold SDM machine picture

Figure 3 shows the main components of the Mold SDM machine. The CNC mill's machining functionality is used to perform all shaping operations. The add-on equipment together with the mill's positioning capabilities performs material deposition and curing.

The CNC mill is used to perform all XY motion, as well as the Z motion for the dispensers. The vertical positioning of the dispensers is critical since these need to be able to track the part surface accurately in order to deposit material in the right locations. By attaching the dispensers to the ram of the mill, one can use the Z positioning capabilities of the machine. This

makes implementation much easier since it is not necessary to build additional Z positioning hardware that is coordinated with the XY motion of the mill. The ram does have a weight limit, however, so the hardware attached to it should be as light as possible.



**Figure 3:** Automated Mold SDM machine schematic

The dispensers are attached to the ram via pneumatically actuated linear slides to produce an up and a down position. The dispensers are normally held in the up position to keep them clear of the part during machining. To deposit material, the appropriate dispenser is moved into the down position and material deposition begins. When finished the dispenser is retracted back to the up position.

The lights do not need to follow the surface of the part and so their Z positioning requirements are less strict. They are usually positioned at a set height above the surface and turned on while the part moves back and forth underneath. For these reasons, and to minimize the amount of equipment mounted on the ram, a separate linear actuator moves the lights up and down.

The Slutterback KB10 wax dispensers are commercially available hot melt dispense units which have a heated melt unit and a pump which forces the molten wax along a heated hose to a dispense valve. Since two types of wax must be deposited, one for building containment walls for casting and one for building the mold itself, two wax dispensers are required.

The soldermask dispenser consists of a pneumatically operated EFD 725DA-SS dispense valve. Soldermask is supplied from a pressurized reservoir.

The Uvexs OCU-12C ultraviolet light is used to cure the soldermask. It is a line source 12 inches long with a power intensity of 300 W/in. The light contains an IR filter to minimize the amount of IR light emitted. It is important to minimize the amount of IR light emitted because this will heat the previous layers and may cause warping, or even melting in extreme cases. The Research Inc. 4453-A-10-06 IR area heater is used to preheat the substrate before deposition of wax. This is an IR heat lamp with six 1000W bulbs that covers a 10 in. by 6 in. area. Since neither light covers the entire 12 in. by 12 in. area of a pallet, curing or preheating operations are performed by scanning the part back and forth under the light.

Control of the integrated CNC deposition/milling machine is performed using both the CNC mill's built-in controller and an external computer, as shown in Figure 4. The computer controls the deposition and curing apparatus via digital and analog I/O and sends motion commands to the CNC controller by downloading CNC program files via an RS232 serial line. The mill also has four relay closure outputs and a digital input that can be controlled and monitored from within the CNC program in order to synchronize the mill's motion with the deposition and curing operations. During a curing operation, for example, the mill will move the part below the UV light, set one of its outputs and wait. When the computer detects that output signal, it turns on the UV light and signals the mill to continue. The mill then begins to move the part back and forth under the light.

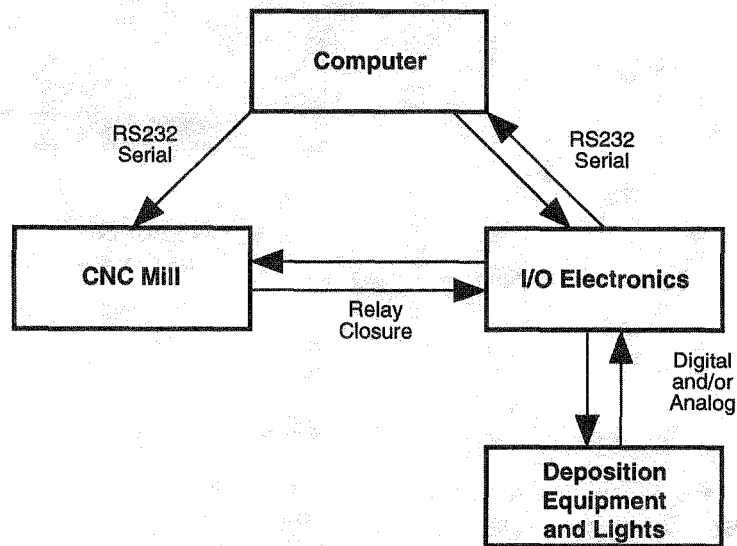

Figure 4: Machine control schematic

## EXAMPLE PARTS

A variety of castable part materials have been used to make parts using Mold SDM. Polymer parts have been made using polyurethanes and epoxy. Ceramic parts have been made using alumina and silicon nitride gelcasting formulations. Pre-assembled mechanisms have also been built in both polymer and ceramic materials.

Figure 5 shows three multi-material turbine assemblies. The epoxy rotor consists of eight curved blades between two discs. A captive polyurethane shaft passes through a hole in the center of the rotor. The rotor is free to spin around the shaft. The diameter of the rotors is 30 mm. These assemblies were built with radial clearances as small as 0.20 mm between the shaft and rotor.

In an effort to determine minimum feature sizes for Mold SDM a set of miniature alumina turbines were built. These are shown in Figure 6 in front of a full size part. The miniature turbines are 7 mm in diameter and 3 mm tall. The section thickness is 0.5 mm.

Figure 7 shows a simplified aircraft engine vane part made of alumina. This part is about 60 mm tall.

Figure 8 shows a part called the Inchworm. It features two pairs of wheels with ratchets mounted to a flexible backbone. The ratchets prevent the wheels from turning backwards. Pressing down on the backbone rolls the front wheels forward, releasing the backbone allows the rear wheels to roll forward in turn, thus moving the Inchworm forward. Unfortunately the wrong clearances were used in the actual parts and as a result the ratchets do not work. The Inchworms

were also the first Mold SDM parts made using multiple cavity molds. This allowed the wheels to be cast using colored polyurethane to distinguish them from the backbone.

The part shown in Figure 9 is a pitch shaft for a missile guidance system. This part demonstrates the ability of Mold SDM to build curved surfaces without stairsteps.

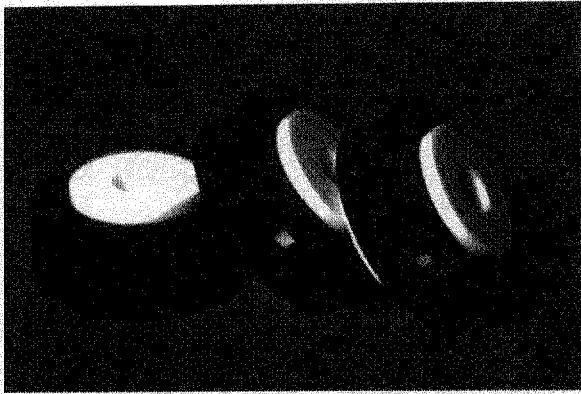

**Figure 5:** Multi-material turbines

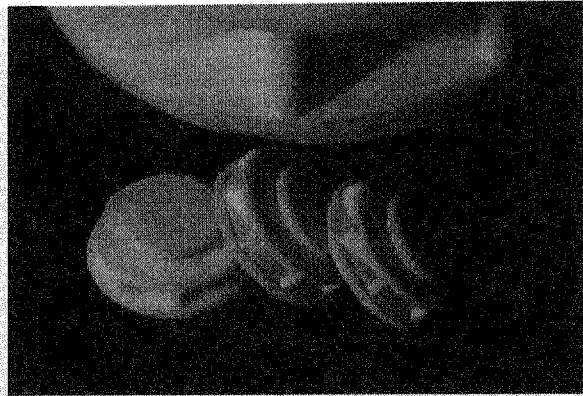

**Figure 6:** Miniature alumina turbines

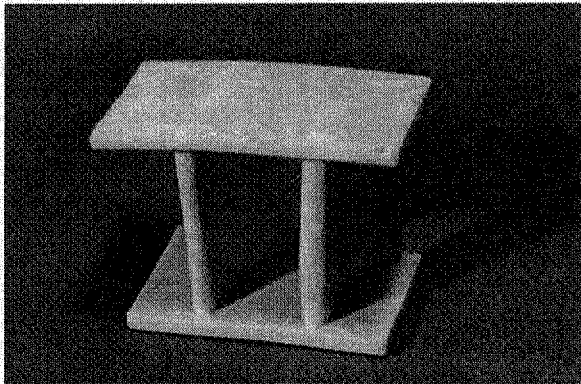

**Figure 7:** Alumina vane

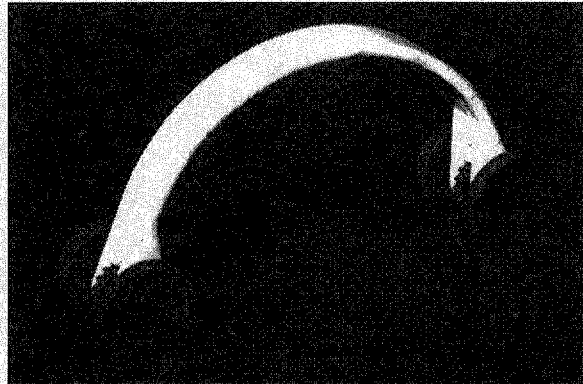

**Figure 8:** Multicolor polyurethane Inchworm

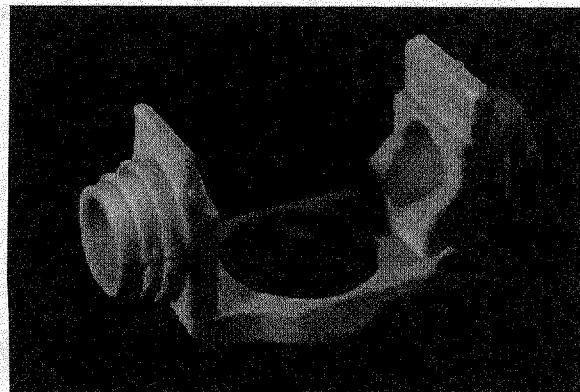

**Figure 9:** Alumina pitch shaft

## CONCLUSION

The Mold SDM process was developed to enable the fabrication of high quality complex ceramic parts. It is an additive-subtractive layered manufacturing process that builds complex fugitive molds. The use of CNC milling to shape all geometry results in smooth accurate surfaces. Since the final part material is cast monolithically there will be no layer boundaries in the finished part.

The Mold SDM process has been automated by the addition of deposition and curing hardware to a commercially available CNC milling machine. Parts have been made without manual intervention using this machine.

Alumina and silicon nitride ceramic parts have been made by gelcasting. Other castable materials, such as polyurethane and epoxy, have also been used successfully.

## ACKNOWLEDGMENTS

The authors would like to acknowledge Shelley Cheng for building the miniature turbine parts as well as David Miller and Brad Levin for building the Inchworm parts. The authors would also like to acknowledge Tom Hasler for his advice and help with all aspects of machining and CNC mill operation. The authors would also like to acknowledge Larry Schultz, Blake Tennison, and Mark Carter for their assistance with process automation equipment.

This work was supported by the Defense Advanced Research Projects Agency under contract N00014-96-1-0625. Additional support was provided by a Department of Energy Integrated Manufacturing Pre-Doctoral Fellowship.

## REFERENCES

- [1] R. Merz, F. B. Prinz, K. Ramaswami, M. Terk, and L. E. Weiss, "Shape Deposition Manufacturing," *Proceedings of the 1994 Solid Freeform Fabrication Symposium*, The University of Texas at Austin, August 1994, pp. 1-8.
- [2] F. Prinz and L. Weiss, "Method for Fabrication of Three-Dimensional Articles," U. S. Pat. No. 5,301,415, April 12, 1994.
- [3] J. W. Kietzman, A. G. Cooper, L. E. Weiss, L. Schultz, J. L. Lombardi, and F. B. Prinz, "Layered Manufacturing Material Issues for SDM of Polymers and Ceramics", *Proceedings of the 1997 Solid Freeform Fabrication Symposium*, The University of Texas at Austin, Austin, Texas, August 1997, pp. 133-140.