

EJECTION FORCES AND FRICTION COEFFICIENTS FROM INJECTION MOLDING EXPERIMENTS USING RAPID TOOLED INSERTS

M. E. Kinsella¹, B. Lilly², B. Carpenter², K. Cooper³

¹Air Force Research Laboratory, ²The Ohio State University, ³NASA Marshall Space Flight Center

Abstract

Experiments have been performed with injection mold inserts made using solid freeform fabrication processes in an effort to further study such applications for economic production of small quantities of parts. Static friction coefficients were determined for HDPE and HIPS against P-20 steel, sintered LaserForm ST-100, and stereolithography SL 5170 using the ASTM D 1894 standard. Injection mold inserts were constructed of the same three materials and were used to inject cylindrical parts using HDPE and HIPS. Ejection forces were measured, and a model was used to calculate ejection forces and apparent coefficients of static friction. Statistical analyses were used to determine the effects of packing time, cooling time and packing pressure on ejection force for the three insert types. This paper compares experimental and calculated ejection forces, compares standard friction test results to calculated apparent coefficients of friction, summarizes the statistical results, and comments on the feasibility of using rapid tooled inserts for injection molding.

Background

Equations developed for the ejection force for deep injection molded parts derive from the friction-based concept $F_R = f \times p_A \times A$, where F_R is the ejection (or release) force, f is the coefficient of friction between the mold and the part, p_A is the contact pressure of the part against the mold core, and A is the area of contact. The version developed by Menges et al defines contact pressure as

$$p_A = E(T) \times \Delta d_r \times s_m \quad (1)$$

and therefore ejection force is:

$$F_R = f \times E(T) \times \Delta d_r \times s_m \times 2\pi L \quad (2)$$

where $E(T)$ is the modulus of the thermoplastic part material at ejection temperature, Δd_r is the relative change in diameter of the part immediately after ejection, s_m is the thickness of the part, and L is the length of the part in contact with the mold core [1].

Two important aspects of the above ejection force model are shrinkage and friction. Shrinkage results from thermal contraction and directional distortion [2]. Thermal contraction is

due to atomic vibration in which atoms move closer together at lower energy levels, and directional distortion results from orientation of polymer molecules during flow, and their subsequent relaxation back to a coiled state after flow ends. Shrinkage is greatly influenced by ejection temperature and varies for amorphous and semicrystalline polymers. Semicrystalline materials exhibit greater shrinkage due to phase transformation of the crystalline portion. Amorphous polymers, on the other hand, contract much more gradually.

Friction between the thermoplastic part and the injection mold core not only depends on the mechanical relationship between the two surfaces, but also on an adhesive component inherent in the properties of the two materials at processing conditions. While the deformation (or mechanical) component of friction tends to be more easily defined, the adhesion component is rather more complex. In adhesive bonding, the surface tension of the adhesive is less than the free surface energy or critical surface tension of the adherend [3]. This allows the adhesive to wet and spread. Heat serves to increase the ability of the adhesive to absorb, dissolve, and disperse. Pressure and heat together improve wetting and spreading of more viscous materials. For polymers, the surface forces consist of van der Waals, coulombic and possibly hydrogen bonding forces [4]. The higher the surface free energy of the polymer, the greater the adhesive force. Very clean metal surfaces may promote chemical bonding.

In this work, the ejection force, modulus, relative change in diameter, and thickness were all determined experimentally as described below. Measured ejection forces were compared with those calculated from the model above, and standard friction testing provided a comparison for the calculated friction values.

Testing and Experimentation

The two rapid tooled injection mold inserts for this research were built using laser sintering and stereolithography processes. The sintered insert was built using LaserForm ST-100, a polymer-coated 420 stainless steel-based powder, which was sintered and subsequently infiltrated with bronze. The stereolithography insert was built using SL 5170 resin material from Vantico.

The thermoplastic materials used for this research were high density polyethylene (HDPE), a crystalline polymer, and high impact polystyrene (HIPS), an amorphous polymer. The HDPE material was Lutene-H ME9180 from LG Chem. The HIPS material was BASF PS 495F. Both materials are commonly used for injection molding applications.

Friction testing was conducted under three temperature conditions following the ASTM D 1894 standard, using the same thermoplastic and mold insert materials described above. The tests were intended to compare coefficients of friction among injection mold insert materials, at elevated temperatures that more closely resembled processing conditions, and to friction coefficients calculated using experimental data and the ejection force model. The friction test matrix is shown in Table 1.

The first temperature condition was room temperature, 22 °C (71 °F). The second condition was ejection temperature, i.e., the temperature at which molded parts are ejected from the injection molding machine. The third condition consisted of first heating to an elevated temperature, then cooling down to ejection temperature before testing. While at the elevated temperature, a 0.9 kg (2-lb) mass was placed on the sled. When the plate cooled to ejection temperature, the weight was removed and the specimen tested. The purpose of the third temperature condition was to imprint the surface of the plate specimen onto the sled specimen. This simulated the environment as well as the surface condition that occurs during ejection of a molded part.

Elastic moduli for the HDPE and HIPS materials used in this research were measured at various temperatures using ASTM D 638 “Standard Test Method for Tensile Properties of Plastics.” Modulus results are shown in Figure 1.

The experimental injection molded part was a closed-end, straight cylinder with a 32 mm (1.26 in) outside diameter, 49.6 mm (1.95 in) height, and 1.2 mm (0.05 in) wall thickness (Figure 2). The canister is designed with four vent holes in the base to prevent vacuum forces that would result during ejection from the core.

A modular mold design was employed, consisting of a steel Master Unit Die (MUD) mold base and a core and cavity that can be removed and replaced with those of other materials. Figure 3 shows the baseline core and cavity, made of P-20 steel, and the two rapid tooled core and cavity sets, made of SL 5170 epoxy resin and LaserForm ST-100 material. Each rapid tooled insert was machined to fit properly into the mold base. The baseline P-20 insert core and the SL 5170 insert core each had a surface finish of $R_a = 0.7$ microns (28 microinches), and the ST-100 insert core had a surface finish of $R_a = 0.3$ microns (12 microinches).

	Plate Specimen	Sled Specimen	Temporary Load	Initial Plate Temp	Soak Time	Plate Temp at Pull
Ambient	P-20 Steel	HDPE	None	RT 22 °C (71 °F)	N/A	RT 22 °C (71 °F)
	P-20 Steel	HIPS	None	RT 22 °C (71 °F)	N/A	RT 22 °C (71 °F)
	ST-100 (Sintered)	HDPE	None	RT 22 °C (71 °F)	N/A	RT 22 °C (71 °F)
	ST-100 (Sintered)	HIPS	None	RT 22 °C (71 °F)	N/A	RT 22 °C (71 °F)
	SL 5170 (Resin)	HDPE	None	RT 22 °C (71 °F)	N/A	RT 22 °C (71 °F)
	SL 5170 (Resin)	HIPS	None	RT 22 °C (71 °F)	N/A	RT 22 °C (71 °F)
Ejection Temp	P-20 Steel	HDPE	None	50 °C (120 °F)	1 min	50 °C (120 °F)
	P-20 Steel	HIPS	None	50 °C (120 °F)	1 min	50 °C (120 °F)
	ST-100 (Sintered)	HDPE	None	50 °C (120 °F)	1 min	50 °C (120 °F)
	ST-100 (Sintered)	HIPS	None	50 °C (120 °F)	1 min	50 °C (120 °F)
	SL 5170 (Resin)	HDPE	None	55 °C (130 °F)	2 min	55 °C (130 °F)
	SL 5170 (Resin)	HIPS	None	55 °C (130 °F)	2 min	55 °C (130 °F)
Elevated Temp	P-20 Steel	HDPE	0.9 kg (2 lbs)	120 °C (250 °F)	1 min	50 °C (120 °F)
	P-20 Steel	HIPS	0.9 kg (2 lbs)	150 °C (300 °F)	1 min	50 °C (120 °F)
	ST-100 (Sintered)	HDPE	0.9 kg (2 lbs)	120 °C (250 °F)	1 min	50 °C (120 °F)
	ST-100 (Sintered)	HIPS	0.9 kg (2 lbs)	150 °C (300 °F)	1 min	50 °C (120 °F)
	SL 5170 (Resin)	HDPE	0.9 kg (2 lbs)	120 °C (250 °F)	2 min	55 °C (130 °F)
	SL 5170 (Resin)	HIPS	0.9 kg (2 lbs)	150 °C (300 °F)	2 min	55 °C (130 °F)

Table 1: Friction test matrix.

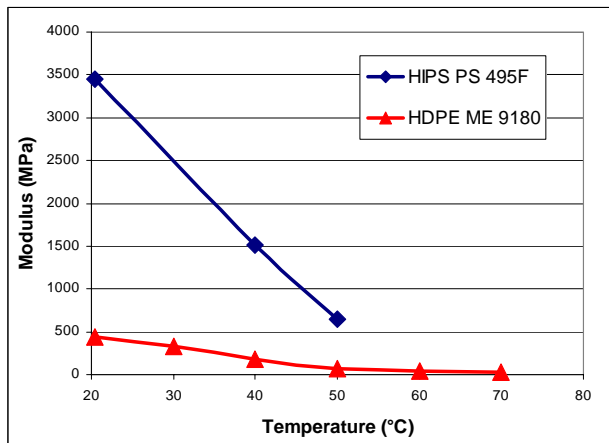

Figure 1: Elastic modulus at various temperatures for HDPE and HIPS.

The SL 5170 cavity was tapered slightly (0.42°) to alleviate problems with parts sticking in the cavity when the mold was opened. This modification, however, did not completely eliminate the problem, and the experiments were completed using the P-20 cavity with the SL 5170 core. Process parameters for each insert and thermoplastic material combination are shown in Table 2.

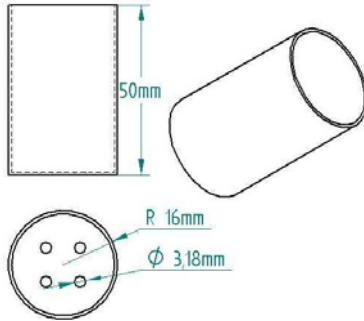

Figure 2: Canister part with vent holes and no taper.



Figure 3: Core and cavity inserts, before final machining, made of SL 5170 (left), P-20 steel (center), and LaserForm ST-100 (right).

The mold was designed with one cavity and a heated sprue connecting directly to the base of the canister. Core temperature was measured using three thermocouples positioned at different depths inside each core insert. Four subminiature load cells were used for measuring ejection force, one each positioned between an ejector pin and the mold ejector plate. A Sumitomo Injection Molding Machine, model SH50M, was used for the experiments. Digital imaging was used to measure inside and outside diameters of each part.

A statistical experiment was designed to determine the effects of packing time, cooling time, and packing pressure on ejection force. In the experiments with P-20 and ST-100 inserts, there were two levels of packing time (2 and 6 seconds), three levels of cooling time (5, 10, and 15 seconds), and three levels of packing pressure (0, 5, and 10 percent of maximum, or 0, 10.93, and 21.87 MPa), eight repetitions each. In the experiments with the SL 5170 insert, there were two levels each of packing time (2 and 6 seconds), cooling time (120 and 150 seconds), and packing pressure (0 and 5 percent of maximum, or 0 and 10.93 MPa), five repetitions each.

HDPE P-20 & ST-100 Inserts	Velocity: 35% or 56 mm/s (2.2 in/s)					
	Temperature Profile:	Sprue	Nozzle	Front	Middle	Rear
		210°C	210°C	199°C	193°C	177°C
HIPS P-20 & ST-100 Inserts	Velocity: 40% or 64 mm/s (2.5 in/s) for P-20, 35% or 56 mm/s (2.2 in/s) for ST-100					
	Temperature Profile:	Sprue	Nozzle	Front	Middle	Rear
		221°C	221°C	213°C	204°C	191°C
HDPE SL 5170 Insert SL or P-20 Cavity	Velocity: 25% or 40 mm/s (1.6 in/s)					
	Temperature Profile:	Sprue	Nozzle	Front	Middle	Rear
		177°C	177°C	171°C	166°C	160°C
HIPS SL 5170 Insert SL or P-20 Cavity	Velocity: 40% or 64 mm/s (2.5 in/s)					
	Temperature Profile:	Sprue	Nozzle	Front	Middle	Rear
		210°C	216°C	202°C	193°C	182°C

Table 2: Injection molding parameters.

Only a limited number of parts could be processed using the SL 5170 cavity due to deformation that caused sticking of parts. The designed experiment, therefore, was carried out using the SL 5170 core with the P-20 cavity. This greatly changed the thermal performance of this insert and reduced the temperature at ejection.

Plate Material	Surface Roughness	HDPE Static Friction Coefficient						HIPS Static Friction Coefficient					
		Room Temp		Ejection Temp		Elevated Temp		Room Temp		Ejection Temp		Elevated Temp	
P-20 Steel	0.7 microns	0.26	+0.08 -0.07	0.31	+0.04 -0.02	0.28	+0.06 -0.02	0.36	+0.04 -0.04	0.32	+0.04 -0.04	0.35	+0.11 -0.21
LaserForm ST-100	0.2 microns	0.21	+0.02 -0.03	0.26	+0.04 -0.05	0.25	+0.01 -0.01	0.32	+0.08 -0.05	0.13	+0.03 -0.02	0.54	+0.17 -0.29
SL5170 Resin	3.6 microns	0.37	+0.04 -0.07	0.45	+0.07 -0.05	0.38	+0.02 -0.02	0.43	+0.05 -0.03	0.56	+0.11 -0.13	5.47	+2.65 -2.08

Table 3: Standard friction test results for HDPE and HIPS.

Friction Test Results

Coefficient of friction results from the standard tests are shown in Table 3. At room temperature, the friction coefficient of HIPS was larger than that of HDPE on all three plate materials. Also, the friction coefficients of both thermoplastics on the SL 5170 plate were higher than those on the metal plates.

Temperature did not make a dramatic difference in friction coefficient for HDPE on P-20, ST-100, or SL 5170. In all cases, elevating the initial temperature to imprint the surface of the specimen was presumed to increase the friction coefficient. It is noted, however, that the imprinted pattern was not very pronounced on the HDPE specimens. Therefore, the temperature to which the specimens were heated may not have been high enough to sufficiently soften the polymer.

The HIPS friction results were much more diverse than the HDPE results. HIPS on both P-20 and ST-100 showed a slight decrease in coefficient from room temperature to ejection temperature, and an increase to elevated temperature. The increase was not significant for P-20, but was rather pronounced for ST-100.

The HIPS friction coefficients increased with temperature on the SL 5170 plate. At ejection temperature, the friction coefficient is significantly higher than at room temperature, and at elevated temperature, the friction coefficient is dramatically higher. This extreme coefficient is attributable to adhesion, resulting from secondary forces between the two material surfaces [5].

Injection Molding Results

Ejection force results from the injection molding experiments are shown in Table 4. Ejection forces for HDPE from the P-20 core, averaged per run, were generally lower than from the ST-100 core, which were lower than from the SL 5170 core. Ejection forces for HDPE from the combination SL 5170/P-20 insert were higher than from the SL 5170 insert.

In contrast to HDPE, ejection forces for HIPS from the P-20 core, averaged per run, are greater than from the ST-100 core for 12 out of 18 runs. Ejection forces from the SL 5170 core are much higher than from the other two. Also in contrast to HDPE, ejection forces for HIPS from the SL 5170 insert are larger than those from the combination SL 5170/P-20 insert.

From the P-20 and ST-100 inserts, ejection forces for HIPS were higher than for HDPE for all experimental runs. Two HDPE runs and three HIPS runs were completed with the SL 5170 core and cavity. For this insert, and for the SL 5170 insert with the P-20 cavity, ejection forces for HIPS were much higher than for HDPE.

Calculations

Ejection forces were calculated from the Menges model and compared with experimental results averaged across all runs (Figure 4). Calculated values differ from actual values due in part to differences in measured and actual friction coefficients. Apparent coefficients of friction were calculated using the Menges model and compared with standard friction test results (Figures 5 and 6). Calculated values of the apparent coefficient of friction were higher than the standard test results due to differences in temperature and pressure. The Menges model provided reasonable estimates of static friction coefficients during ejection.

			Experimental Ejection Force			
			HDPE		HIPS	
Packing Time s	Cooling Time s	Packing Pressure %	P-20 Steel N	LaserForm ST-100 N	P-20 Steel N	LaserForm ST-100 N
2	5	0	177.15	182.30	343.97	366.29
2	5	5	183.29	190.02	376.37	389.51
2	5	10	186.52	209.79	401.48	375.28
2	10	0	176.51	177.44	346.11	375.71
2	10	5	185.89	196.61	385.56	393.54
2	10	10	172.87	194.33	408.26	394.47
2	15	0	191.90	196.15	384.60	366.31
2	15	5	174.68	201.68	381.94	393.56
2	15	10	173.08	208.75	403.70	398.83
6	5	0	184.69	173.95	376.97	363.86
6	5	5	193.58	185.81	395.23	378.14
6	5	10	173.88	184.41	393.38	388.07
6	10	0	171.28	172.12	369.19	369.54
6	10	5	174.63	178.83	390.81	360.58
6	10	10	175.19	180.87	391.73	374.38
6	15	0	170.00	170.97	351.62	340.67
6	15	5	180.05	186.82	394.77	370.57
6	15	10	185.53	184.13	424.46	399.88

			HDPE		HIPS	
Packing Time s	Cooling Time s	Packing Pressure %	P-20 Steel N	LaserForm ST-100 N	P-20 Steel N	LaserForm ST-100 N
2	120	0			1334.27	
2	150	0	239.06		1136.12	
2	180	0	193.21			
2	150	5			1512.25	
2	120	0		274.21		695.76
2	120	5		299.65		826.28
2	150	0		258.76		610.12
2	150	5		278.18		845.02
6	120	0		313.33		770.24
6	120	5		297.38		939.13
6	150	0		321.09		702.28
6	150	5		317.93		892.15

Table 4: Experimental ejection force results for HDPE and HIPS according to packing time, cooling time, and packing pressure parameters.

DOE Results

Analysis of variance results are shown in Table 5. Packing time had an effect on both thermoplastics with both rapid tooled inserts, and on HIPS across the board. Cooling time had an effect on both thermoplastics with the P-20 insert, and on HDPE only with the ST-100 insert. All three factors had an effect on HIPS with the P-20 mold insert. In the case of the baseline P-20 insert, effects are very different between the two thermoplastics. For the two rapid tooled inserts, there is not as much difference in effects between the two thermoplastics. Interaction effects are shown on the right side of the table.

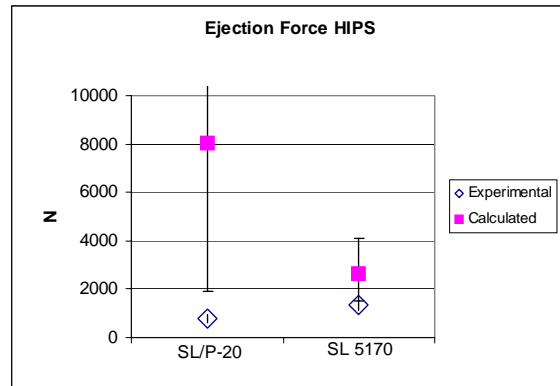
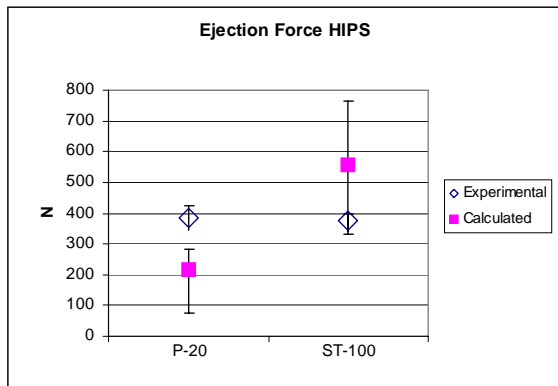
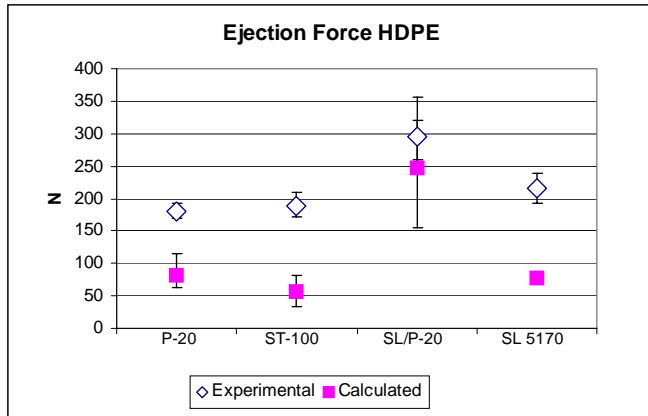

Figure 4: Experimental compared with calculated ejection forces for HDPE (top) and HIPS.

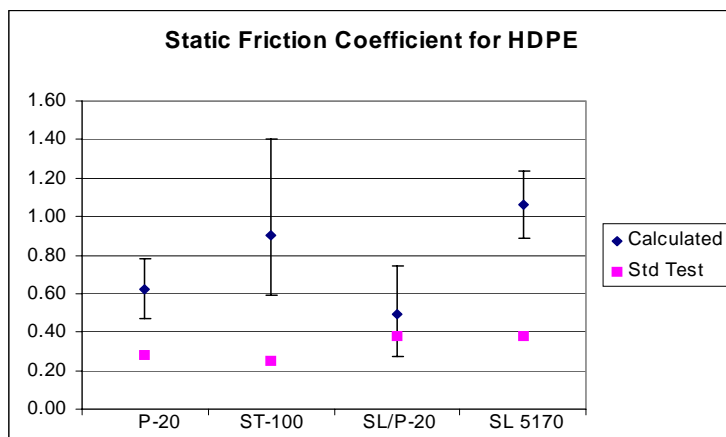

Figure 5: Coefficients of friction calculated from experimental results compared with those from standard friction tests for HDPE, all four inserts.

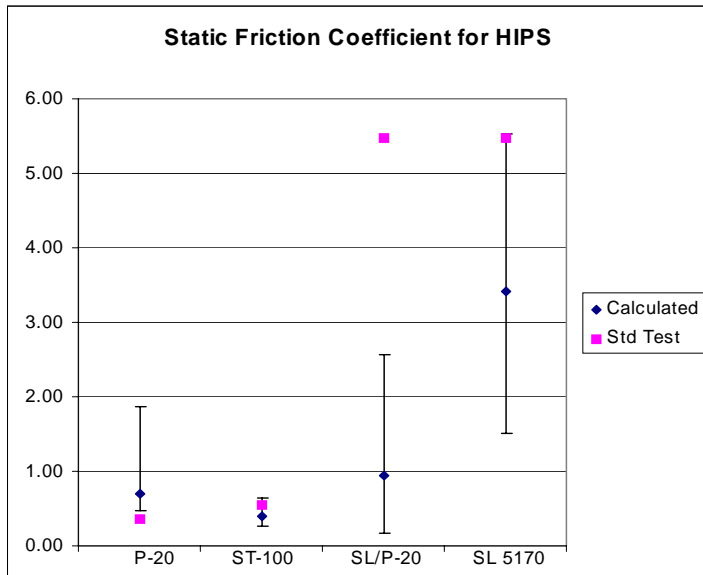

Figure 6: Coefficients of friction calculated from experimental results compared with those from standard friction tests for HIPS, all four inserts.

HDPE							
Insert Material	Factors			Interactions			
	Packing Time T_p	Cooling Time T_c	Packing Pressure P_p	T_p - T_c	T_p - P_p	T_c - P_p	T_p - T_c - P_p
P-20 Steel		✓					✓
Sintered ST-100	✓	✓		✓			✓
SL 5170/P-20	✓						
HIPS							
Insert Material	Factors			Interactions			
	Packing Time T_p	Cooling Time T_c	Packing Pressure P_p	T_p - T_c	T_p - P_p	T_c - P_p	T_p - T_c - P_p
P-20 Steel	✓	✓	✓	✓	✓	✓	✓
Sintered ST-100	✓			✓		✓	✓
SL 5170/P-20	✓		✓				

Table 5: Results from the designed experiment indicating which factors had a significant effect on ejection force.

Other Observations of Rapid Tooled Inserts

The ST-100 insert held up well for the number of parts that were processed, and had every indication that it would last for many more. There were differences in data between the ST-100 and P-20 experiments, however, indicating that there are thermal and adhesion differences that affect ejection force and friction coefficient.

The SL 5170 insert operated quite differently from the other two metal inserts. The resin core held up for more than 105 full parts, with minimal flashing and no catastrophic failure. A few anomalies with the SL 5170 insert were observed during processing, including adhesion, core swelling, internal defects, and deformation. Adhesion of the part to the SL 5170 core occurred with both thermoplastics, but to a much greater extent with HIPS.

Defects internal to the SL 5170 core are shown in Figure 7. After the SL 5170 core processed about 40 parts, it began to show some internal defects, which looked like internal delaminations along the layers of the tool. The core, however, lasted through the entire experiment without these defects propagating into failure.

Deflection of the SL 5170 cavity wall during injection had the greatest negative effect in the injection molding experiments. The wall of the cavity apparently deformed elastically under injection pressure. Then, although the part began to shrink, too much material had been forced into the mold, and was held fast by the cavity wall.

In a preliminary study of this deformation, the SL 5170 insert was modeled using an ABAQUS finite element analysis. Results show that the walls of the cavity do indeed elastically deform in a way that would cause parts to stick. In Figure 8, deformation of the SL 5170 by HDPE injection, no packing, is concentrated near the base of the cavity, with a maximum magnitude of 0.06 millimeters (0.002 inches). Similar results were found with HIPS. When packing was included, the magnitude of the deformation of HIPS was greater and encompassed a greater area along the cavity wall.

Conclusions

The Menges model provides a reasonable method for estimating ejection forces and can predict coefficients of static friction between the part and the core during ejection, given that accurate inputs to the model are available. Standard friction tests at elevated temperatures result in coefficient values that are closer to those during processing. The two environments, however, are not identical, so measured friction coefficients are not the same as those during processing. The coefficient of friction between HIPS and SL 5170 is very high due to excessive adhesion. Both the standard tests at elevated temperature and the experimental injection molding results show this.

The ST-100 insert held up with no signs of wear or damage. For the given quantities, the ST-100 performed just as well as the P-20. The SL 5170 insert is capable of limited processing of HDPE, but is not recommended for processing HIPS due to high adhesion. The core was durable enough to process more than 105 parts with no catastrophic failure. The major difficulty with the SL 5170 insert was deformation of the cavity during ejection, which caused parts to stick in the cavity when the mold opened. Other issues with the SL 5170 core included core swelling and the development of internal defects after approximately 40 processing cycles.



Figure 7: Defects in the SL 5170 core.

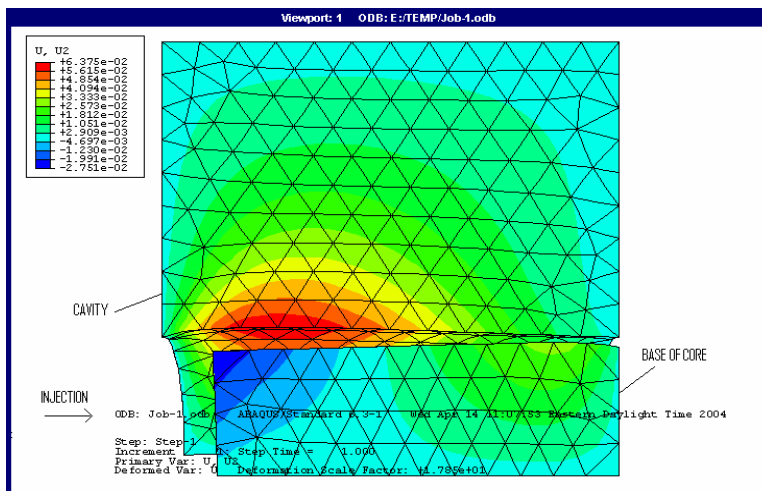

Figure 8: Simulation results of HDPE injection into SL 5170 insert, no packing.

References

1. Menges, G., Michaeli, W., Mohren, P. 2001, *How to Make Injection Molds*, Hanser Gardner Publications, Munich, Cincinnati.
2. Burke, C., Malloy, R. 1991, "An Experimental Study of the Ejection Forces Encountered During Injection Molding," *ANTEC 1991*, pp. 1781-1787.
3. Cagle, C.V. (ed.) 1973, *Handbook of Adhesive Bonding*, McGraw-Hill, New York.
4. Briscoe, B.J. 1981, "Wear of polymers: an essay on fundamental aspects," *Tribology International*, August, pp. 231-243.
5. Wu, S. 1982, *Polymer Interface and Adhesion*, Marcel Dekker, New York.