

MULTIPLE MATERIAL MICRO-FABRICATION: EXTENDING STEREOLITHOGRAPHY TO TISSUE ENGINEERING AND OTHER NOVEL APPLICATIONS

Ryan Wicker*, Francisco Medina*, and Chris Elkins**

*University of Texas at El Paso, W.M. Keck Border Biomedical Manufacturing and Engineering Laboratory, Department of Mechanical and Industrial Engineering, El Paso, Texas 79968-0521

**Stanford University, Department of Mechanical Engineering, Stanford, California 94305-3030

Reviewed, accepted August 4, 2004

Abstract

A design for modifying an existing 3D Systems stereolithography (SL) apparatus 250/50 was developed to accommodate multiple material fabrication for building multi-material, multi-functional and multi-colored prototypes, models and devices. The machine was configured for automated access to an intermediate washing, curing, and drying unit that eliminated contamination between material vats and maintained accurate platform registration throughout the build process. Three vats were arranged on a rotating vat carousel, and each vat was adapted to actively maintain a uniform, desired level of material by including a recoating device and a material fill and removal system. A single platform was attached to an elevator mechanism (z-stage) to traverse the platform to and from the vats and the washing, curing, and drying unit. The platform was mounted to the z-stage via an automated rotary stage to rotate the platform about a horizontal axis, thus providing angled building, washing, curing, and drying capabilities. A horizontal traversing mechanism was also designed to be optionally included to facilitate manufacturing between multiple SL cabinets, related SL apparatuses and/or other alternative manufacturing technologies. For micro-fabrication, linear and rotary stages were selected that provided $\pm 1.0 \mu\text{m}$ repeatability and $0.1 \mu\text{m}$ resolution and ± 2 arc sec repeatability and 0.13 arc sec resolution, respectively. The multi-material SL design presented here is capable of utilizing existing SL resins for manufacturing multiple material mechanically and electrically functional models as well as hydrogels, biocompatible materials, and bioactive agents for a variety of bio-functional, implantable tissue engineering applications including nerve regeneration and guided angiogenesis.

Keywords: rapid prototyping; multiple material stereolithography; micro-stereolithography; tissue engineering; micro-fabrication

1. Introduction

Stereolithography (SL) is a rapid prototyping (RP) or layered manufacturing technology that utilizes an ultraviolet (UV) laser to selectively cure individual layers through a photopolymerization process solidifying a liquid photo-reactive polymer. A series of optics focuses the beam on the liquid surface while a controllable scanning mirror system rasters the beam across the surface to initiate the solidification reaction. The desired three-dimensional part is first attached to a platform located at the top of the surface of the liquid resin contained in the material vat. The platform is also connected to a vertical traverse (z-stage) that is used to control

the build layer thickness of the part by controlling the location of the part relative to the liquid surface for each successive layer. When building the part simultaneously with its required support structure (since there is only a single material available from which to select for building the part and support) and after the laser beam completes a layer, the platform is traversed vertically downward a distance equal to the build layer thickness. Complex-shaped parts are thus manufactured by repeating the simultaneous part and support structure layering process over the required number of layers. Once complete, the part is typically raised out of the liquid polymer, the support structure is removed from the part, the part is cleaned and then post-cured. There are many RP technologies available for manufacturing complex-shaped parts in addition to SL (see Jacobs, 1996; Wohlers, 2004 as examples), and the work described here is not intended to review these technologies or present advantages and disadvantages associated with them. Rather, we have particular interest in SL for two reasons: its potential use in soft tissue engineering applications such as nerve regeneration and guided angiogenesis as well as its ability to manufacture unique customized functional devices, including micro-fabrication of implantable and other functional structures and devices.

There are a wide variety of photocurable materials, including implantable materials used in tissue engineering, available for use in SL. As a result, there is enormous potential for expanding SL applications. However, current commercial systems are not prepared for these expanded applications, and thus, this work describes the design and development of a multi-material SL system for use in tissue engineering and customized functional device manufacturing. The focus is on designing a retrofit to an existing 3D Systems 250/50 SL machine to provide for directly manufacturing 3D implantable constructs using biocompatible and photocurable hydrogels. Hydrogels are receiving considerable attention in the area of tissue engineering [see Bryant and Anseth, 2001; Drury and Mooney, 2003; Hoffman, 2002; and Liu and Bhatia, 2002 as examples] because of their high water content and biocompatibility. In addition, hydrogels are ideally suited as scaffolding materials due to their similarity mechanically and structurally to extracellular matrix. Many different hydrogels are being used in tissue engineering applications. In our particular application, we are using a smaller subset of hydrogels based on poly(ethylene glycol) (PEG) with a photoinitiator requiring an ultra-violet (UV) light source with wavelength compatible with our current SL lasers (both 325 nm and 355 nm).

One of the most challenging problems in TE is promoting cell in-growth or promoting perfusion to seeded cells in implanted scaffolds. The reason for this is that beyond distances of ≈ 100 microns in the body, the diffusion of oxygen and nutrients is not enough to sustain cell viability. Therefore, perfusion must be designed into a scaffold through not only controlling the different manufacturing scales (such as pore size) but also controlling the location of different materials (such as providing gradients in growth factors required in guided angiogenesis). Many TE projects rely on the necessary fluids and factors reaching the cells through the pores of the scaffold. However, the resolution of commercial SL (approximately 75 microns currently) and its ability to manufacture highly complex 3D objects make it potentially suited for building perfusion promoting scaffolds. There are challenges, however, with employing current SL technology for micro-fabrication, and we have previously reviewed some micro-SL issues (see Wicker *et al.*, 2004). There are additional complications in using multiple materials in SL since all SL systems today are designed as single resin systems. Thus, with the development of the multi-material SL system described here, angiogenic structures or roadways can be built between proliferative structures.

The desire for multiple material SL is not entirely new. Maruo *et al.* (2001), for example, demonstrated use of micro-SL with different photocurable resins. Different resins were used to demonstrate the ability of SL to combine the optical, electrical and mechanical properties of different polymer resins to manufacture micro devices requiring a combination of all or some of the above properties. Recent work by Liu and Bhatia (2002) demonstrated a photolithographic process for manufacturing hydrogel microstructures using a manual lithographic masking process. The success of their approach, which is similar to SL, motivated our approach. We believe there are enumerable potential applications for multiple material SL, and we present here our design and development of a multiple material SL machine. Design specifications include a multiple material SL system that maintains a non-contaminating and sterile building environment between materials by accommodating an intermediate washing, curing, and drying cycle between build materials. Additional benefits of this design include building multiple material implantable hydrogel structures for tissue engineering, and allowing additives such as color, cells, or rigid embedded devices to be incorporated into materials on a layer by layer basis. It also allows other materials to be added or integrated in the parts to alter characteristics, such as the strength, mechanical, optical, thermal, electrical, functional and bio-functional properties on a layer by layer basis or even within a single layer. The following describes the development of this technology, several alternative designs, and several sample multiple material SL applications.

2. Multiple Material Stereolithography Machine Design

2.1. Multiple Vat Design (Retrofit to Existing 3D Systems 250/50)

A perspective view of the multi-material SL machine is depicted in Figure 1. As mentioned previously, our desire was to design a multiple vat carousel system to fit within the current space of a 3D Systems 250/50 SL machine. There are several elements of the machine, including the rotating vat carousel, rotating platform, pump fill and remove system, and wash, cure, and dry unit. These sub-systems are described in more detail below, while the operation of the machine is described in the section that follows.

The rotating vat carousel consists of three stainless steel vats located 90 degrees from one another circumferentially and attached to a rotary stage via a shaft. Thus, the vats can be rotated about a vertical axis (the axis of the shaft) in order to position different vats underneath the platform. One vat position is left open so that the platform has access to the wash, cure, and dry unit located at the bottom of the machine (to be described in more detail below). For the retrofit to the small frame 250/50 machine, the vats were designed with a cross-section of 5-in by 5-in and depth of 3-in. A high accuracy direct drive rotary was selected for the vat rotary as well as the platform rotary (to be described below) having ± 2 arc sec repeatability and 0.13 arc sec resolution. Direct drive rotary stages were selected because of their accuracy and repeatability, small size, sealed enclosure, and load capacities. For different design requirements, larger size platforms and vats can be accommodated with a retrofit to a larger frame machine or a new machine altogether. In this particular case, the vats were designed to be located at the original liquid level height of the machine and sized to fit within the existing framework.

Although a variety of materials could be used for the platform depending on the application, a stainless steel platform was machined to fit in the vats (the platform was designed to have 4.5-in by 4.5-in cross-sectional area). Similar to the commercial machine, the platform was attached to a z-stage, although a high precision linear, sealed traverse with ± 1.0 μm repeatability and 0.1 μm resolution was selected. The platform was attached to the z-stage via an additional rotary

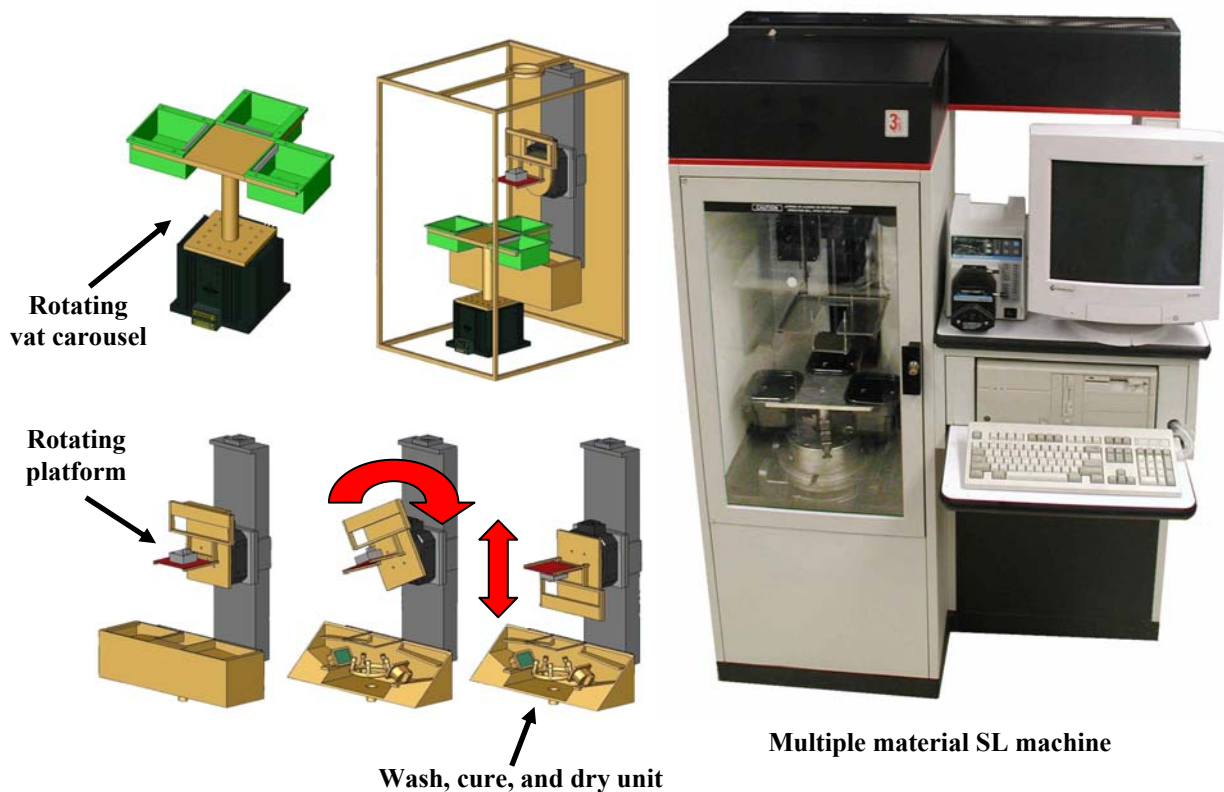

Figure 1. Multiple vat carousel designed to fit within a 3D System 250/50 SLA machine, also incorporating intermediate wash, cure, and dry cycle for multiple material fabrication.

stage in order to provide for angled part building, washing, curing, and drying. Thus, the platform can be manipulated vertically as well as at any given angle about a horizontal axis as needed to customize building the part. In addition, recoating technologies can also be employed in this machine by incorporating them individually in each vat. At the present time, however, sweeping is not currently used during part building.

Since we had multiple vats and we needed to implement a strategy for filling and removing material from the vats as well as a strategy for controlling liquid levels in each vat, we employed a pump fill and remove system as shown in Figure 2. The peristaltic pump shown allows isolation of the vat material from the moving parts of the pump while providing a means for mechanically adding and removing precise quantities of fluid to and from each vat. In the design described here, build layer thicknesses can be controlled to 0.5-mil (13 μm) using the pump system alone (i.e., without moving the platform). In our design, we have also developed a vat overflow drain system that maintains a constant liquid level within an associated vat by continuously pumping liquid into the vat via the pump. Each vat is configured with two fluid chambers, the main vat chamber and the overflow drain chamber. The main vat chamber is configured such that the platform fits within it, and the overflow drain chamber is designed to drain overflow material back to the material reservoir. The volume of the main vat chamber may be adjusted by repositioning a vertical leveling gate. Currently, liquid level sensing is accomplished manually as well as employing the existing laser level sensor. Other strategies for

accurately sensing both the liquid level and the platform location during the build are in development.

A key element of our multiple material SL system is the addition of a wash, cure and dry unit that is accessible to the platform (and thus, the part) at any time during the build (see Figure 1). This strategy enables multiple materials to be used without loss of part registration and without contamination between materials. The wash, cure, and dry unit consists of an enclosure that houses a washing system (typically using alcohol), two UV lamps for intermediate resin curing, and heating and cooling capabilities for drying any alcohol or other residue prior to immersing the platform and part in the next vat of material. The platform and platform rotation system are further designed to mate into and thereby seal an enclosure over the washing, curing, and drying unit in order to eliminate overspray or material contamination on other functional equipment within the multi-material SL machine.

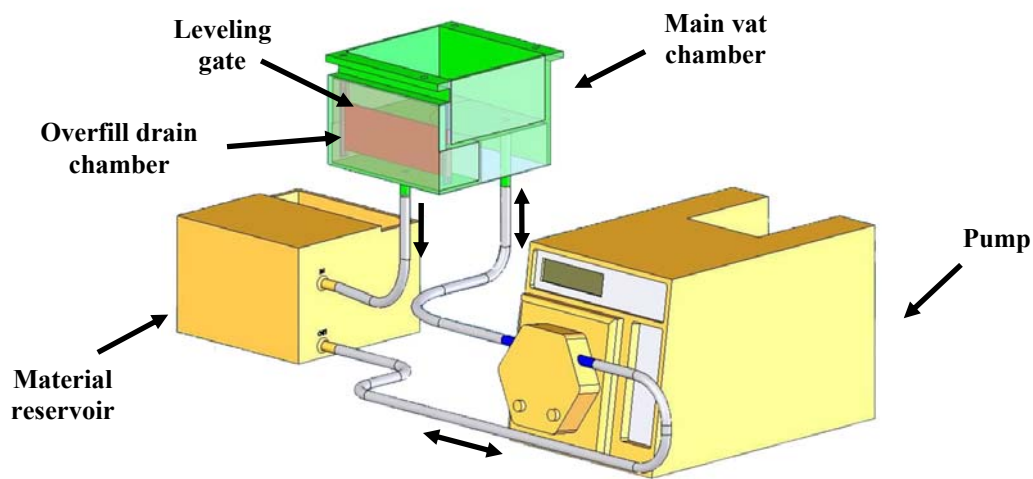

Figure 2. Individual vat fill and removal system design.

2.2. Brief Multiple Material Fabrication Operation Overview

The major components of the multi-material SL system were described in the previous section and we briefly describe the operation of the system in this section for a simple multiple material build. Figure 1 remains appropriate for reference during the description of the operation. In order to change materials after building with one material, the platform is raised out of the vat, and the vats are rotated out of the way so that the elevator mechanism can be traversed into the washing, curing, and drying unit (or wash area). If sealed washing is desired, the platform is rotated 180°, traversed down to the wash area sealing the enclosure; otherwise the platform can be traversed to the wash area and washing, curing, and drying can occur at any angle. Once in the wash area, the platform and the part are washed using the ring jet dispensing system located at the bottom of the wash area. Virtually any solvent or wash fluid can be used; we typically use alcohol, which is appropriate for traditional SL resins. Any waste from the washing unit remains contained within the enclosure for proper disposal. After washing, the part can be UV-cured, heated, or convectively cooled to provide curing and drying as required.

After the desired washing, curing, and drying procedures are completed, the moveable platform is returned to a position above the vats so that the vats can be rotated underneath the

platform. Once the desired material vat is located beneath the platform, the platform is immersed into the next build material. Accurate fabrication and micro-fabrication is accomplished with accurate positioning, sensing and feedback. Thus, we have specified precise stages, designed a precise material fill and removal system, and, as mentioned above, we are developing strategies for accurate sensing of the liquid level and platform (or top of the part) for accurate builds.

3. Alternative Machine Designs

The design presented above can effectively accomplish multi-material SL. Multi-material SL provides expanded opportunities for manufacturing a variety of multi-material and multi-functional products. For example, additives such as color can be incorporated into resins within or across layers to facilitate multi-colored SL. The machine further accommodates other material additives such as those that alter the mechanical, optical, thermal, electrical, functional and/or bio-functional properties of the material and ultimately the device. However, retrofitting the system to the small frame machine described above may present prohibitive constraints for a particular application. In order to provide flexibility to multi-material SL, we present several conceptual design alternatives that address a wide variety of desired multiple material fabrication methods. These design alternatives are presented briefly below.

In a particular application, it may be desired to interface an existing single material or multi-material SL machine with other SL machines and/or other manufacturing technologies. For example, these alternative machines may include other additive and subtractive manufacturing technologies as well as quality control and inspection technologies so that the build process can be interrupted to interface with Computer Numerical Control (CNC) milling machines, Coordinate Measuring Machine (CMM) probes and other vision measurement systems, Fused Deposition Modeling (FDM), Selective Laser Sintering (SLS), Layered Object Manufacturing (LOM) and any other RP technology, micro-machining and other cutting systems, painting apparatuses, ink jets and other fluid and particle dispensing mechanisms, and/or other pick and place technologies. With this capability, enormous additional flexibility is afforded multi-material SL.

As an illustration of alternative multi-material and multi-functional machine designs, Figure 3 contains multiple technologies stacked in side-by-side (or linear) arrangements where the

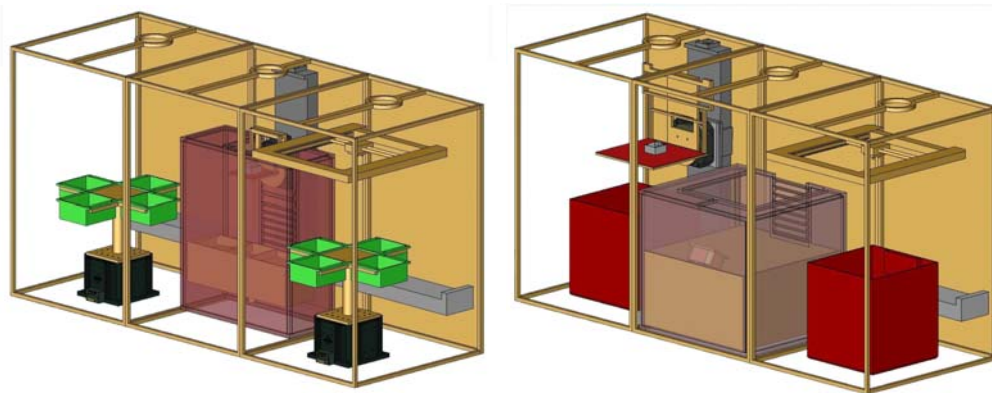

Figure 3. Alternative multiple material SL designs incorporating multiple SL machines and alternative manufacturing technologies placed in a linear arrangement allowing the platform to be moved to different areas of the machine via a horizontal traverse.

washing, curing, and drying unit described previously is located between the various technologies. In Figure 3, two configurations are shown; one in which multiple vat systems similar to the one described in Figure 1 are separated by a wash unit and the other represents two single vat SL systems (such as the 250/50) simply separated by the wash unit. In both examples, the platform system (also depicted with rotational capabilities about a horizontal axis) is mounted on a horizontal linear traverse so that the platform and parts can be transported between technologies and into the wash unit. In order to maintain the integrity of each area, the SL machine may optionally include shielded chamber walls between each area as well as the enclosed wash unit as depicted in the figure.

Another alternative design is depicted in Figure 4 where two platforms are attached to two separate z-stages, placed back to back and positioned on a single rotary stage. In this circular configuration, the two platforms have access to alternative manufacturing technologies, multi-material vats (and/or single vats), and the wash unit. Obviously, virtually any arrangement can be configured to accomplish specific objectives. The number and types of vats, washing, curing, and drying units, horizontal translation mechanisms, alternative manufacturing technologies, and other single or multi-material SL machine elements may be customized to suit virtually any application and/or design criteria. Thus, the multi-material SL machine as described maintains a non-contaminating (and potentially sterile in the case of implantable materials) building environment, while facilitating an increased number of building materials and fabrication technologies.

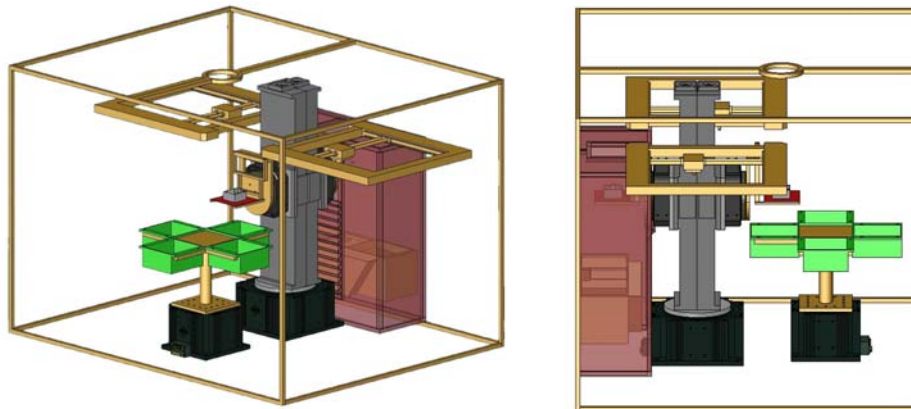

Figure 4. Alternative multiple material SL design incorporating multiple platforms that access different areas of the machine through a rotary stage.

4. Multiple Material Fabrication Demonstrations

To demonstrate successful multi-material fabrication, Figures 5, 6, 7, and 8 illustrate a variety of multiple material applications. The multi-material SL machine is not fully functional at the time of this writing, so all demonstrations were fabricated using existing technologies where considerable effort was required to successfully accomplish the multiple material part. In Figure 5, a multi-material micro-RF switch is shown. Successful fabrication required embedding a precise V-groove metal insert (manufactured by Sandia National Laboratories using a 1-mil wire EDM) and interrupting the build to insert a piece of Teflon that was later removed. We have used Teflon inserts extensively in part fabrication requiring removal of the insert in order to

increase dimensional integrity of downfacing surfaces and eliminate the need for support. In this particular example, multiple manufacturing technologies and materials were required to develop the functional device.

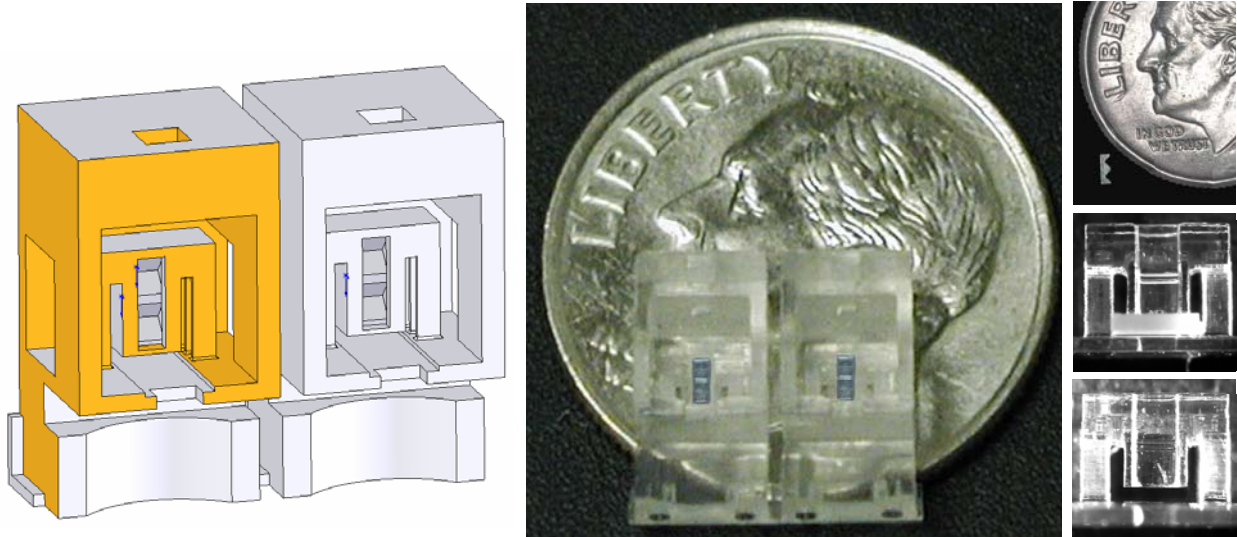

Figure 5. Functional micro-RF relay requiring process interrupt and part embedding (represents collaborative research with Sandia National Laboratories).

Figure 6 contains a demonstration where a conductive ink was deposited on top of a ProtoTool™ block of material, the ink was thermally cured, and then a block of WaterShed™ was deposited on top using SL. The concept and our research of using SL to fabricate functional electronics were described previously by Palmer *et al.* (2004). This represents an interesting example of the need for multi-materials for manufacturing functional and three-dimensional electronics to be used in a variety of applications including homeland security, national defense, space, aerospace, and others.



Figure 6. Conductive ink deposited on top of ProtoTool™ base material with a clear WaterShed™ top surface (represents collaborative research with Sandia National Laboratories).

Figure 7 contains three different geometries of implantable hydrogel constructs manufactured using SL. The top row of the figure contains multi-lumen conduits that are utilized for nerve

regeneration. In this example, multiple materials are required to manufacture the multi-lumen conduit for nerve regeneration where hydrogels are the base material and different and potentially bioactive agents are located within the conduits to assist in nerve regeneration. The second row of pictures shows various embedded channels to be used for guided angiogenesis. The first two images of the second row highlight FITC Dextran placed in an embedded channel illuminated with a blacklight. The green conduits represent food coloring mixed into the hydrogel during the build. The hydrogel construct that appears to have a “Y” geometry located within it represents a 400 micron channel bifurcating into two 250 micron channels. These constructs with precisely placed growth factors within the channels are to be implanted in rats to test the ability of these constructs to generate arterial growth when attached to the rat’s femoral artery.

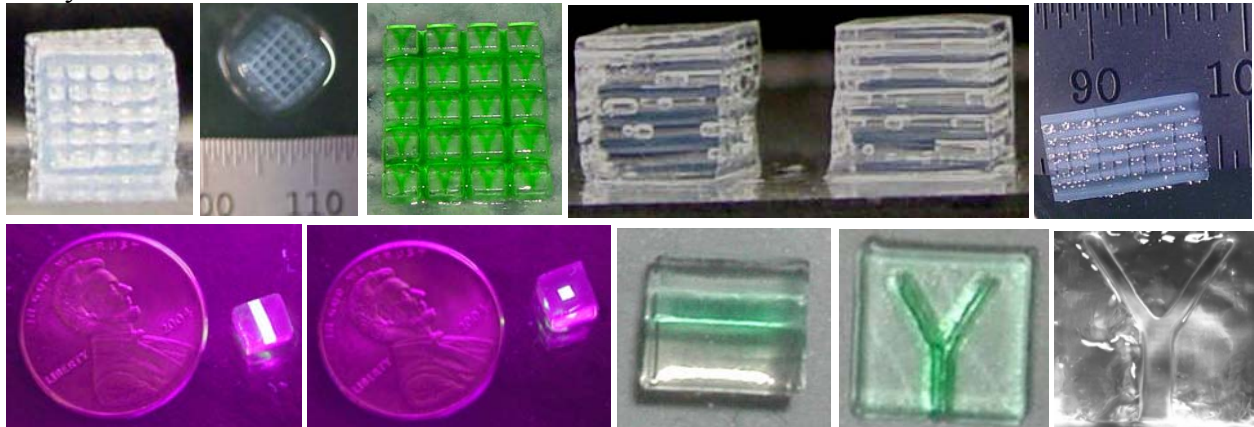

Figure 7. Complex multi-material hydrogel constructs manufactured using stereolithography for nerve regeneration and guided angiogenesis applications.

Figure 8 contains an SL model of a tumor embedded in the mandible of a 15-year-old patient, where the model was fabricated for a pre-surgical planning application demonstrating the need for multi-colored SL. In this example, only two colors are shown which can currently be accomplished using a commercial resin such as RenShape™ SL Y-C 9300 selectively colorable resin. However, it can be appreciated that there are certainly applications similar to this one where multiple colors are required. Using the multi-material SL technology described here, multi-colored prototyping involving any number of colors can be accomplished. In Figure 8, pigments were selectively mixed into epoxy and injected into the tumor to provide the color, and a similar procedure can be effectively used in the multi-material SL machine.



Figure 8. Multi-colored SL model highlighting tumor in mandible of 15-year-old patient.

5. Concluding remarks

A design for modifying an existing 3D Systems SL apparatus 250/50 was described to build cost-efficient and timesaving multi-material, multi-functional and multi-colored prototypes, models and devices. The design was configured for intermediate washing, curing, and drying between materials to avoid material contamination. A design was implemented that included three vats arranged on a rotary stage, where the vats were adapted to actively and/or passively maintain a uniform, desired level of material by including a material fill and remove system. The platform and part were accessible to the vats and the washing, curing, and drying unit using a precision linear traverse. In addition, the platform was attached to the linear traverse via a rotary stage to provide for angled part building and washing, and also to provide the ability to make a sealed enclosure on the wash unit. The wash unit was configured to provide washing, curing, and drying capabilities that were central to accomplishing multi-material SL. In addition to the implemented design, several alternative designs were presented that provide exceptional flexibility in unique customized functional device manufacturing. Although this work was motivated by our research in developing implantable tissue engineered constructs and functional device manufacturing, the technology presented here can be applied to a wide variety of applications.

Acknowledgments

The research and development presented here was performed at UTEP in the W.M. Keck Border Biomedical Manufacturing and Engineering Laboratory (W.M. Keck BBMEL) using equipment purchased through Grant #11804 from the W.M. Keck Foundation. This material is based in part upon work supported by the Texas Advanced Research (Advanced Technology/Technology Development and Transfer) Program under Grant Number 003661-0020-2003, and a grant from the state of Texas Tobacco Settlement Funds. This work also benefited from our collaborative research with Sandia National Laboratories through the Laboratory Directed Research and Development (LDRD) Program Contract #28643 under the technical direction of Dr. Jeremy Palmer. There are many students in the W.M. Keck BBMEL involved in research related to the work presented here, and we are particularly appreciative of the efforts of Lindsay Adams, Karina Arcaute, Oswaldo Lozoya, and Luis Ochoa. The nerve regeneration tissue engineering application briefly presented here was introduced to us by Professor Brenda Mann at the Keck Graduate Institute and her continued participation in our research is appreciated. The opinions expressed in this paper are those of the authors and do not necessarily reflect those of any other individuals, UTEP, Stanford University, or any sponsors of the W.M. Keck BBMEL or its research.

References

- Bryant, S.J., Anseth, K.S., "The effects of scaffold thickness on tissue engineered cartilage in photocrosslinked poly(ethylene oxide) hydrogels," *Biomaterials*, Vol. 22, pp. 619-626, 2001.
- Drury, J.L., and Mooney, D.J., "Hydrogels for tissue engineering: scaffold design variables and applications," *Biomaterials*, Vol. 24, Number 24, November 2003, pp. 4337-4351.
- Hoffman, A.S., "Hydrogels for biomedical applications," *Advanced Drug Delivery Reviews*, Vol. 43, pp. 3-12, 2002.

- Jacobs, P.F., "Stereolithography and other RP&M technologies from rapid prototyping to rapid tooling," Published by Society of Manufacturing engineers in cooperation with the Rapid Prototyping Association of SME, Dearborn, Michigan, 1996.
- Liu, V.A., Bhatia, S.N., "Three-dimensional photopatterning of hydrogels containing living cells," *Biomedical Microdevices*, Vol. 4. No. 4, pp. 257-266, 2002.
- Maruo, S., Ikuta, K., Ninagawa, T., "Multi-polymer microstereolithography for hybrid opto-MEMS," *MEMS 2001. The 14th IEEE International Conference on Micro Electro Mechanical Systems*, 2001, January 21-25, 2001, pp. 151-154.
- Palmer, J.A., Yang, P., Davis, D.W., Chavez, B.D., Gallegos, P.L., Wicker, R.B., and Medina, F., "Rapid Prototyping of High Density Circuitry," *Rapid Prototyping & Manufacturing 2004 Conference*, Society of Manufacturing Engineers, 2004.
- Wicker, R.B., Ranade, A., Medina, F., and Palmer, J., "Practical Considerations for Micro-Stereolithography of Embedded Micro-Channels," *Proceedings of the Rapid Prototyping & Manufacturing 2004 Conference*, Society of Manufacturing Engineers, 2004.
- Wohlers, T., "Wohlers Report 2004: Rapid Prototyping, Tooling and Manufacturing, State of the Industry," Wohlers Associates, Annual Worldwide Progress Report, 2004.