

MANUFACTURE OF COMPLIANT PROSTHESIS SOCKETS USING SELECTIVE LASER SINTERING

Sean Stephens*, Richard Crawford*, William Rogers[†], Andrew Gitter[†], and Gordon Bosker[†]

*The University of Texas at Austin

[†]The University of Texas Health Science Center in San Antonio

Abstract

Solid Freeform Fabrication to date has largely been applied in prototype fabrication or fabrication of patterns for conventional manufacturing methods. However, many opportunities exist for using SFF for manufacturing the actual product. In particular, those applications that require or can be enhanced by custom geometric design seem to be well suited for SFF techniques. In this paper we describe the design of a prosthesis socket for a below-the-knee amputee. This socket is specifically designed to provide compliance in selected areas to enhance the comfort of the wearer. Additionally, the socket contains an integrated pylon fitting that provides a structurally superior connection while also improving the comfort of the wearer. The socket was manufactured using selective laser sintering, mated to a pylon and foot, and fitted to the patient for gait analysis. The results of the analysis indicate an improved fit is possible with manufacture by SLS.

Introduction

There are more than 400,000 living limb amputees in the United States, and about 60,000 new amputees every year. Ninety-seven percent of these amputees could benefit from prostheses to assist in locomotion. Experts think it would take 70,000 new, well-trained prosthetists to meet the current needs with the current technologies. Rogers et al. (1991) have pointed out that using CAD/CAM techniques to manufacture prosthetic limbs is the only viable way to serve this large population in a reasonable time frame. The purpose of the research reported herein is to demonstrate the combination of CAD techniques with solid freeform fabrication (SFF) to produce custom prostheses with superior performance.

The socket is the most important part of a below-the-knee (BK) prosthesis. An example is shown in Figure 1 (a). The socket is the interface between the residual limb and the mechanical structure that supports the patient on that limb. Ultimately the socket defines the comfort level and energy expenditure of the patient. The socket design is directly related to the level of acceptance the patient has for the prosthesis. In the first year after an amputation, the residual limb changes shape, so the patient is usually fitted with a temporary, or check socket. After the first year has passed, a stronger, better fitting socket can be made. This is called the definitive socket and should last for at least one year.

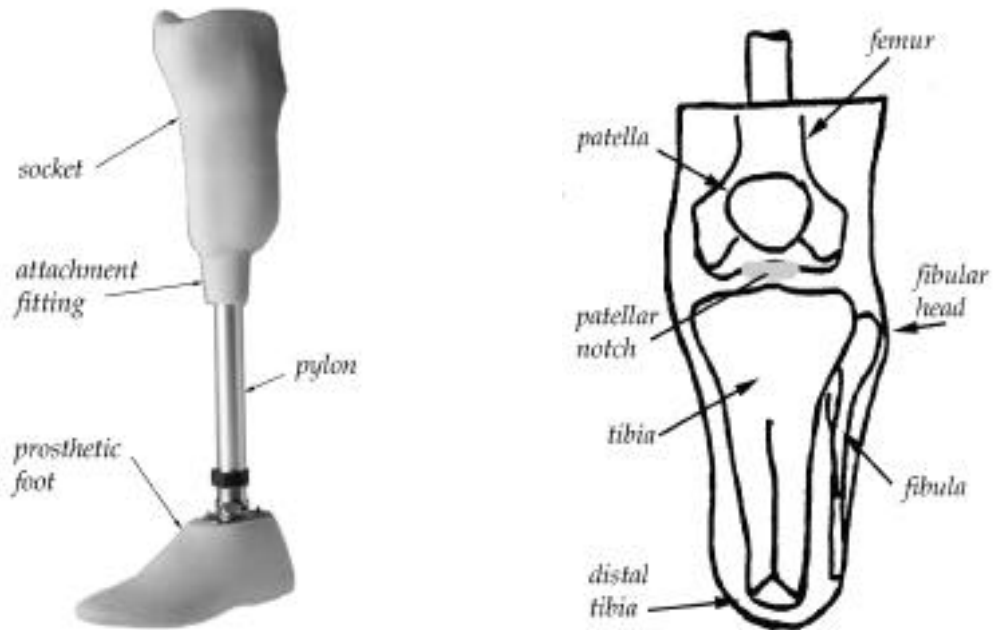

Figure 1. (a) Below-the-knee prosthetic leg. (b) Left front view of a left BK residual limb.

Discomfort when wearing a socket is primarily caused by high pressure on the residual limb tissue, especially in sensitive bony areas, such as the fibular head and the distal end of the amputated tibia. Figure 1(b) shows these landmarks on a residual limb sketch. One way to reduce this pain is to relieve the areas that are sensitive by reducing the stiffness of the socket in these areas. The stiffness necessary for support can be transferred to areas where the tissue is less sensitive and more appropriate to use for support. We propose to provide this selective compliance by locally modifying the geometry of the socket to provide areas of selective compliance and stiffness. *We contend that SFF, specifically selective laser sintering, is particularly suited for manufacturing sockets with this geometric complexity.* We also contend that the custom nature of the sockets makes SFF an appropriate choice for their manufacture. And we claim that SFF enables the inclusion of an integral pylon fitting, providing superior performance in terms of patient comfort and durability of the socket.

Related Work

The current socket fabrication method used by Department of Rehabilitation Medicine and Radiology of The University of Texas Health Science Center in San Antonio (UTHSCSA) begins with a moldable air-hardening sock placed over the residual limb. The prosthetist manually forms and marks the sock around certain landmarks as the sock hardens. This sock is then carefully removed and placed on a rotating platform to be laser scanned. The prosthetist uses specially developed software to manipulate the scanned shape of the socket depending on the patient's needs. This involves relieving, or pushing out, certain areas like the fibular head and the distal tibia, as well as several other modifications to ensure comfort and proper function. The final socket data are sent to a CNC mill to machine a positive out of plaster. The plaster positive is attached to a vacuum forming machine and a socket is made from a 3/16" thick sheet

of polyethylene/polypropylene blend plastic. Finally, the top of the socket is trimmed and the fitting for the pylon is attached. This process, though on the way to becoming automated, is still very labor intensive. Additionally, the socket produced by this vacuum forming process does not have a consistent, or even predictably inconsistent, wall thickness.

Rogers, et al. (1991) studied the feasibility of producing BK sockets using SLS. In this study, UTHSCSA used their laser scanning input device and socket modification software.¹ After the design is complete, the file was converted to the STL format, and a standard 30mm pylon fitting with an initial alignment was added. The parts were initially scaled down and produced in polycarbonate on the prototype SLS machine at UT Austin. A full size socket was then produced in nylon by DTM Corp. in Austin, Texas. This full size prototype was not used functionally by a patient. However prosthetists on staff at UTHSCSA believed that the socket is at least as functional as sockets produced by the existing vacuum form process.

Squirt Shape is a rapid prototyping technology developed at the Northwestern University Prosthetics Research Laboratory (Rovick, 1992). This manufacturing method was developed to address the need for rapidly creating prosthetic sockets. Squirt Shape is an additive manufacturing process similar to Fused Deposition Modeling (FDM) by Stratasys, Inc., Eden Prairie, MN. Squirt Shape extrudes molten plastic along a line that spirals up along the contour of the socket being produced. Prior to fabrication, the CAD contour is “sliced” into a spline-interpolated, helical pathway for the machine controllers to follow. The socket is fabricated by a plastic extrusion head that moves radially above a rotating fabrication stage. As the continuous bead of plastic is deposited according to the coordinates defined by the slicing algorithm, layers are formed on top of one another to create the object. As the plastic is deposited it begins cooling and hardens. Rovick reported in 1992 that a 9 inch BK socket can be produced in 1.5 hours (Rovick et al., 1998). Although this process produces a socket extremely quickly, the long-term performance of the sockets has not been established. Also, this technique can only produce single layer sockets of a consistent wall thickness and therefore is very similar to the capabilities of vacuum forming.

Freeman and Wontorcik (Freeman and Wontorcik, 1998) performed a cost-benefit analysis on using stereolithography for producing test sockets. They showed that SLA is viable as a process to produce test sockets. However the method was not feasible with regards to cost. They found that SLA sockets of 0.250 and 0.156 in. wall thickness were “... strong enough to support the patient during ambulation for one hour.” Even though the sockets worked as test sockets, the authors were still careful to state that both SLA resins used were “... very brittle and would not be suitable for the high stress that occurs in a definitive socket.” Due to the overall cost and the time to produce one piece, the Freeman and Wontorcik conclude that at this time SLA is not viable as a test socket fabrication method. However, the sockets did work within their material limits and had comfort and fit “similar to previous test sockets made of copolyester by traditional methods of vacuum forming.”

This is a very good benchmark for the manufacturability of a definitive socket using SLS. Because SLS materials are much more functional and robust than SLA materials, a socket made

¹ UTHSCSA has since partnered with Seattle Limb Systems to further develop and commercialize their scanner and software systems.

with SLS should withstand the stresses that a definitive socket must bear over time. Because of the similarity of the technologies, the cost is probably similar. Though \$900 was not tolerable for a test socket, it is much more acceptable for a definitive socket, especially one that can better address the issues of comfort and fit than existing vacuum formed sockets.

Design of a Double Wall Socket

To provide selective flexibility and rigidity as required for comfort and functional gait support the most straightforward solution is changing the thickness of the socket wall. There are two configurations this solution can take. The first is a single wall concept that satisfies the needs of high and low compliance in a series fashion. Areas that need to be rigid are thicker than a nominal thickness, and flexible areas are thinner. The needs of flexibility and rigidity can also be approached in a parallel manner with double-walled socket. The inner wall is thin, providing flexibility, and the outer wall is thick for rigidity. The compliance of the inner wall can be localized by adding “compliance elements,” or features designed to provide a specific degree of compliance in target areas. Struts are added between the two walls to properly support the leg and to distribute the forces from the inner wall to the outer wall. The double-walled configuration is the subject of this study.

Design of Compliance Elements

A series of experimental prototypes were fabricated to test different concepts for compliance elements. Two SLS materials, both developed by DTM, were used: Protoform and Duraform. Both are derived from nylon and have similar properties. Protoform is difficult to process and is significantly more stiff and brittle. Duraform was developed by DTM to be a very robust processing powder. Thus, Duraform was chosen as the socket material.

Figures 2, 3, and 4 illustrate the several test panels fabricated in Duraform. The first piece, Test Panel 1, is meant to primarily determine the minimum possible wall thickness and to illustrate effects of adding thicker ribs of material. Panels 2 and 3 (Figures 3 and 4) show several different options for using a cantilever structure similar to a leaf spring. The cantilevers tested are 60°, 90°, and 120° triangles. In the second panel two slot widths were also tested, 0.020” to 0.040”, with and without chamfering. It is important to keep this width small to help prevent pinching, but it has to be large enough to prevent adjacent cantilevers from fusing together during fabrication.

There are two other panels tested, but they are simply the thick and thin halves of the third panel. These half panels were oriented vertically, while the three full panels were flat. Again, the reason for this is to observe if there are appreciable differences depending on layer orientation. To prevent the faces from fusing across the bottom, the internal edges were chamfered.

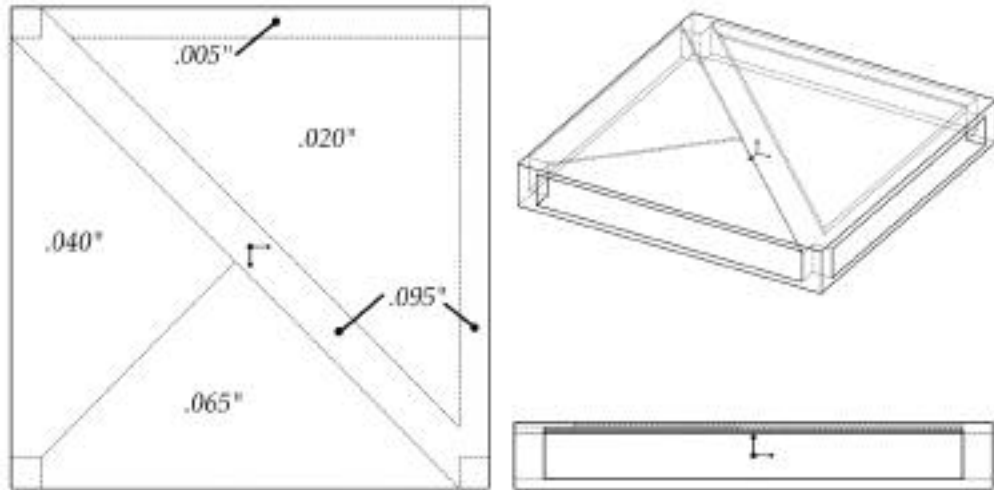

Figure 2. Duraform test panel 1.

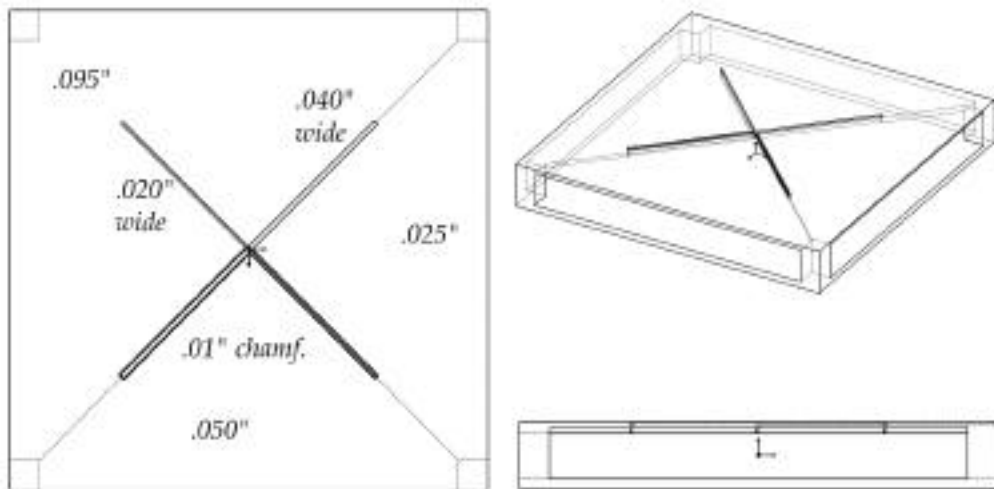

Figure 3. Duraform test panel 2.

The Duraform powder used for these samples was recycled once. The parts were fabricated with no difficulties. The Duraform prototypes are all shown in Figure 5. It is interesting to note the color difference depending on the thickness of the material: the lighter the color, the thinner the material. With the recycled powder there is still some difficulty getting consistent properties in a vertically built wall, as evidenced by the striations in the half panels.

The 0.020" thick region on the panel 1 design is thin enough to actually be like a flexible membrane. With about 20 psi applied, the stretch of the material can be seen and felt. It is fairly plain this thin material would not last long enough to make it viable in a socket, but the stretch effect is an important observation, perhaps useful in other areas. After many cycles of pushing and pulling on the prototypes, the 0.040" region is the thinnest region without permanent deformation or cracks. Therefore, 0.040" is set as the minimum wall thickness allowed. This is an even more conservative constraint considering the socket has have curved walls and is fabricated from virgin powder, both of which will increase strength and durability.

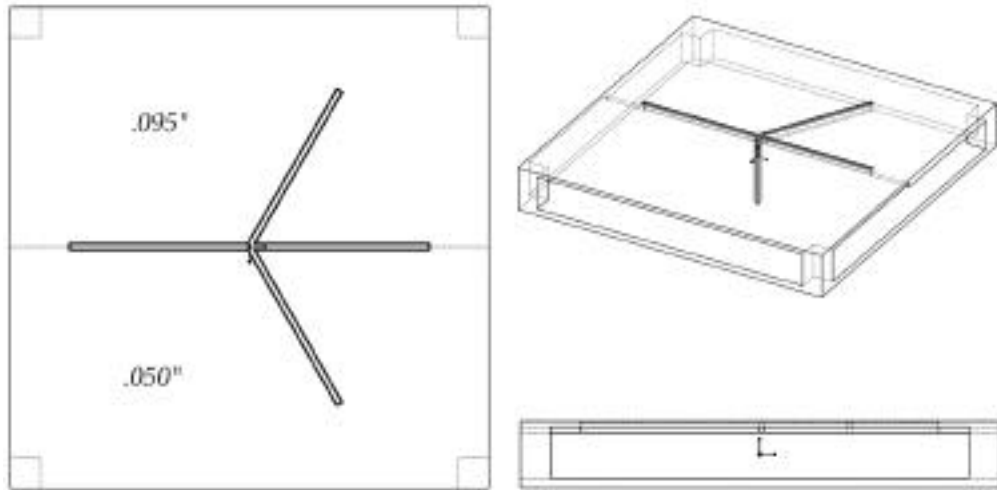

Figure 4. Duraform panel 4.

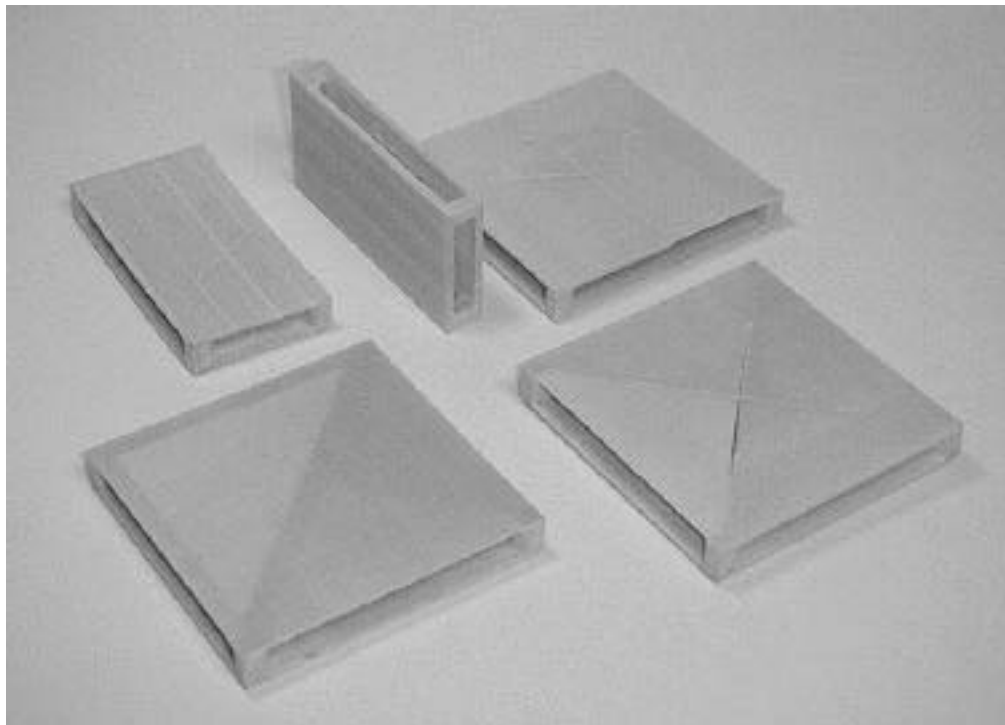

Figure 5. Duraform prototypes.

Although there are laminar striations in the panels that were built vertically, this is due to poor mixing of the recycled powder not the processing of the SLS parts. These striations did not noticeably weaken the two half panels. Also, at this point there is no way to assess the long-term effects of the striated differences in wall material consistency. From a cosmetic standpoint, the striations would certainly be unacceptable. If well-mixed virgin powder is used, this effect will not occur. The fused bottom panel problem was solved by chamfering the inner edges.

Although it is difficult to observe in the figure, the 0.020" slots in the panel 2 design are

fused together. This is caused by thermal growth. This is supported by the fact that the slot between the two thinner regions was freed of the partially fused material by applying a large force to the cantilevers. The slot in the 0.095" material could not be broken loose, which supports the thermal growth theory because the thicker the material the more thermal growth. Therefore, from these results, slots in the wall of the socket need to be 0.040" or greater.

By pushing on the different cantilevers on the test panels, it became apparent that the best design of those considered is the 60° beam. It deflected with a reasonable amount of force and did not affect the material around it as much. The wider the attachment base of the beam, the stiffer it will be there, thus transferring more of the moment into the surrounding structure. With the 90° and 120° samples, the area behind the cantilever was affected noticeably. Since this is not really desirable and the slot length for these wider cantilevers must be longer to attain a certain level of deflection, the final design concept uses the 60° cantilever.

Other design considerations and constraints became apparent after consultation with the prosthetist at UTHSCSA (author Bosker). The primary areas that are uncomfortable in the socket that would benefit from large-scale deflection are the fibular head and distal tibia regions. It was established that the deflections in these areas should not be more than about 2 mm, or 0.079", over a 2" diameter area. This should provide relief without adversely affecting the biomechanics of gait, or causing uncomfortable pressure in a new area.

Software Development

In this research, the data goes through several different software packages before emerging as the final solid model. The flowchart in Figure 6 shows the flow of the information through the different packages. In this section we summarize the data processing; details can be found in (Stephens, 1999).

To begin, the C program "ap1toscm" reads the data from a standard AAOP data file, the file format generated by the UTHSCSA scanner. This data is offset by certain distances to create the basic double wall socket structure. Certain areas of the inner wall have their thicknesses altered from the standard. The information is then written to a file named "wires.m" to be run in Octave, a UNIX-based mathematics program very similar to MatLab².

In Octave, the wires.m script calls two procedures: FitSpline.m and SampleSpline.m. These two operations fit low order spline curves to the point data to reduce and smooth the data. Then the octave file writes "swire.scn", a Scheme file for ACIS.³ Scheme is a language very similar to LISP that is used for rapid development in ACIS.

In the ACIS environment, the script buildsock.scn is run to build the entire socket model from several other Scheme files. The file loftsock.scn takes the individual wire data loaded by swire.scn and creates the basic lofted socket. The compliant elements are defined by tibslot.scn and fibslot.scn. The stiffening supports are added by blocksup.scn and the base fitting is in base.scn. All of these components are combined by the buildsock.scn script.

² MatLab is a technical computing product of The MathWorks, Inc., Natick, MA.

³ The ACIS 3D Toolkit is a commercially available 3D modeling kernel of 35 C++ dynamically linked libraries offered by Spatial Technology, Inc., Boulder, CO.

Once the entire solid model of the socket is complete, the Scheme function “writerawfacets” is used to retrieve the vertices from the model and create a faceted model file. Finally, an awk¹ script, “acis2stl,” is run to rewrite the data in the STL format.

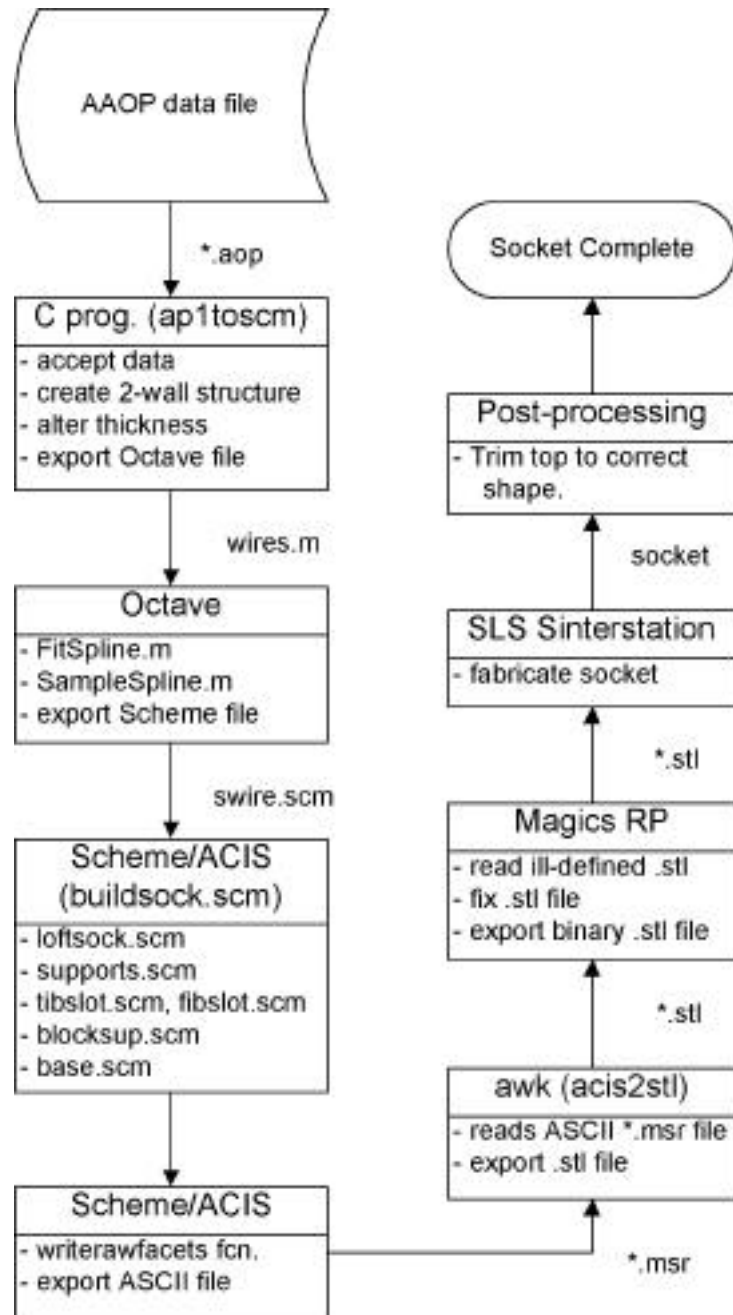

Figure 15. Software usage flowchart.

¹ Awk is a UNIX scripting language for text processing.

Socket Fabrication

A test socket was first produced in the UT Austin Laboratory for Freeform Fabrication using about 75% virgin Duraform and 25% once recycled Duraform. The SLS workstation is an older prototype version that cannot fabricate the entire socket due to height limitations. Figure 7 shows the bottom portion of the socket that was fabricated. In the left view, the fibular head hex-slot and the dual wall construction are visible. . In the right view, the tibial compliance element and the supports can be seen.

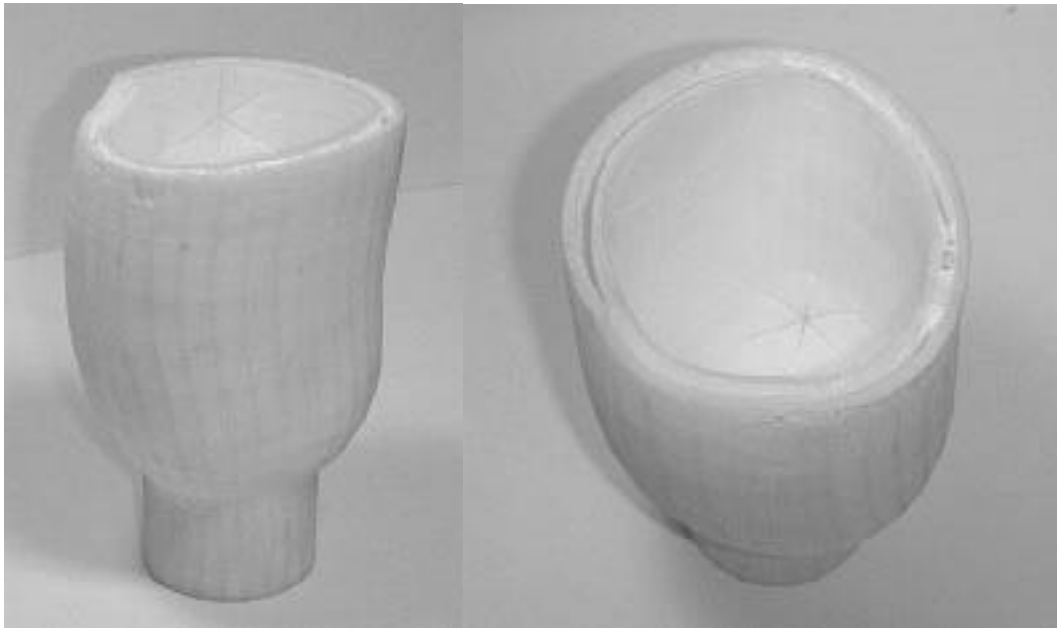

Figure 7. Prototype SLS socket.

The prototype socket proved to be dimensionally inaccurate. The inner diameter of the base is smaller than nominal by 0.115” and the outer diameter is smaller by 0.094”. The depth of the base is smaller by 0.032”. The base side thickness is larger by 0.011”. The fact that the wall is thicker, with all other dimensions being equal points to thermal growth during the build. The decrease in inner and outer diameters points to the x-y coordinates being off by a scaling factor. This was probably caused by a loss of calibration in the laser/mirror system. Neither the scaling factor growth is an issue with current DTM Corp. production machines.

The final socket was produced by DTM Corporation. The socket was fabricated in a horizontal orientation with the front of the knee facing down in the build chamber. Given that a few other parts were built at the same time in the SLS batch, it took approximately 10.5 hours to build with a DTM Sinterstation 2500 plus™ machine. This machine uses 0.004” layers when producing products from Duraform, so it is expected that the accuracy is better. The final SLS socket as produced at DTM is shown in Figures 8 and 9.

The final socket resulted in much better dimensional characteristics. The pylon insert fit tightly into the base fitting, allowing the insert to be press fit without glue or screws to hold it in place. The compliance elements were produced with extreme precision. For instance, the

clearance between the cantilever features in the compliance elements is larger than required when producing the socket on a late model DTM Sinterstation™. In fact, the slots were produced so well there was a concern about the sharpness of the edges and points causing pinching on the patient. Future designs will need to be filleted in this region with a smaller slot width.



Figure 8. Side and bottom views of final socket after SLS fabrication.

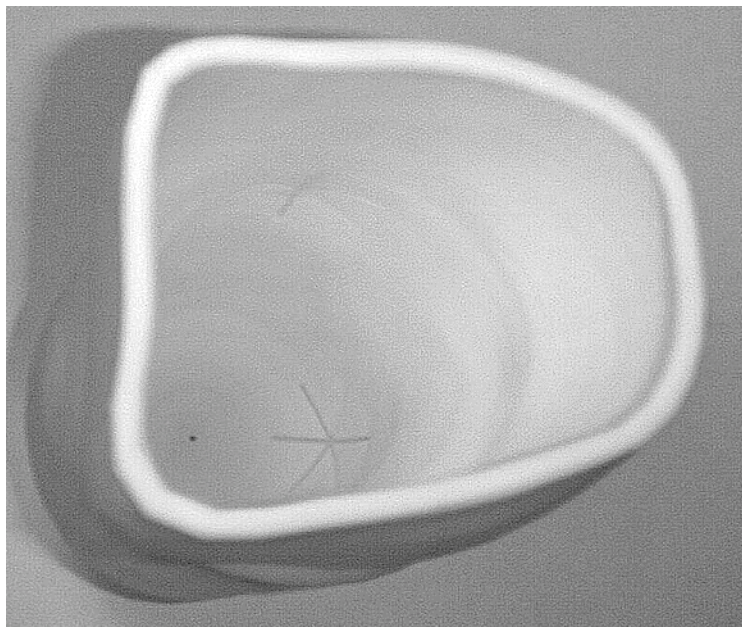

Figure 9. Top view of the final socket, showing the tibial hex-slot.

Analysis of the fabricated socket indicates that the inner wall is thicker than is really necessary, and there are more supports than necessary to provide the stiffness needed. The inner

wall is very stiff and does not appear to deflect noticeably except in the areas of the compliance elements. A future version of this socket design should allow for some small deflection of the inner wall with the only stiff points being at the supports. Care should be taken in this endeavor to ensure that reliability of the socket is not compromised by a thinner inner wall. From a strictly fabrication standpoint, the socket is considered a success.

Patient Fitting of the Socket

After the socket was fabricated, a pre-fitting process was to shape the top of the socket and to attach the pylon and prosthetic foot. After these steps were completed the socket was fitted to the patient, which included checking the actual socket fit and the alignment of the pylon on the bottom of the socket. Once the socket was properly fitted, a clinical test was performed to better evaluate its performance in walking activities. The final socket is shown in Figure 10 after this prefitting process.

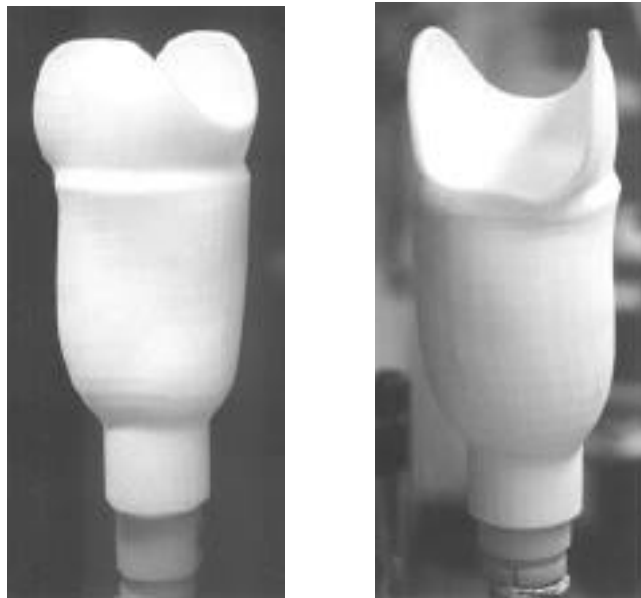

Figure 10. Front-right and rear views of the completed socket.

The completed prosthesis was fitted to the patient (see Figure 11) and subjected to gait analysis at UTHSCSA. The results are summarized here; details can be found in (Rogers et al., 2000). Most importantly for the goals of this research, the patient reported higher socket comfort over conventional sockets. The patient's self-selected walking speed was 3% higher, and he showed improve step length symmetry between the prosthetic and the intact limbs. Although the SLS socket weighed 450 grams more than a carbon fiber socket of conventional construction, this was undetectable by patient.



Figure 11. Patient fitting of the prosthesis.

Conclusion

The goal of this research was to test the hypothesis that higher performing below-the-knee prosthesis sockets can be manufactured by selective laser sintering. The results of the work thus far point toward supporting this hypothesis, as a double wall socket was successfully designed, fabricated, and fit to a patient. Clearly, however, more work is needed before the technology is truly proven. First, more clinical trials are necessary. One patient does not represent a statistically significant sample. Second, while double wall design appears feasible, we are interested in testing single wall sockets as well. Clearly, a single wall socket will require different compliance elements, but offers the possibility of reduced weight. Third, the long-term performance of the SLS socket material is unknown. Fourth, the software environment developed for this research is not appropriate for use by practicing prosthetists. Research is continuing in each of these areas.

Acknowledgements

The authors acknowledge the support of the Veterans Administration for partial support of this work. We also gratefully acknowledge DTM Corporation for donations of material and machine time to fabricate the socket.

References

1. Rogers, W.E., Crawford, R.H., Beaman, J. J., and Walsh, N.E., 1991, "Fabrication of Prosthetic Sockets by Selective Laser Sintering," *1991 Solid Freeform Fabrication Symposium Proceedings*, Marcus, H. L., Beaman, J. J., Barlow, J. W., Bourell, D. L., and Crawford, R. H., eds., Austin, TX, August 12-14, 1991, pp. 158-163.
2. Rovick, J. S., 1992, "An Additive Fabrication Technique for the Computer-Aided Manufacturing of Sockets," *Proceedings, Seventh World Congress of ISPO*, p. 24.

3. Rovick, J. S., Childress, D. S., and Tucker, K., 1998, "Technology Transfer of a Computer-Aided Socket Fabrication Technique (DVA Project No. A0711-D)," URL: <http://pele.repoc.nwu.edu/progress/jrrd.dva.9809.SquirtShape.html>.
4. Freeman, D., and Wontorcik, Leslie, C. P., 1998, "Stereolithography and Prosthetic Test Socket Manufacture: A Cost/Benefit Analysis," *Journal of Prosthetics and Orthotics*, Vol. 10, No. 1, pp. 17-20.
5. Stephens, S. D., 1999, *Design of a Compliant Prosthetic Socket Fabricated Using Selective Laser Sintering*, MS thesis, The University of Texas at Austin, August 1999.
6. Rogers, B, Stephens, S., Gitter, A., Bosker, G., and Crawford, R., 2000, "Double Wall Transtibial Prosthetic Socket Fabricated Using Selective Laser Sintering: A Case Study," *Journal of Prosthetics and Orthotics*, submitted.