

# DESIGN AND MANUFACTURE OF A FORMULA SAE INTAKE SYSTEM USING FUSED DEPOSITION MODELING AND FIBER-REINFORCED COMPOSITE MATERIALS

Ryan Ilardo, Christopher B. Williams  
Design, Research, and Education for Additive Manufacturing Systems Laboratory  
Department of Mechanical Engineering  
Virginia Polytechnic Institute and State University  
Randolph Hall, Blacksburg, VA, 24061-0238  
(540) 231-3422; cbwilliams@vt.edu

## ABSTRACT

In this paper, the authors discuss the design and manufacture of an intake system for a 600cc Formula SAE engine. Specifically, Fused Deposition Modeling is used to create an intake system (consisting of a plenum, plenum elbow, and cylinder runners) that is then later covered in layers of carbon fiber composite fabric through vacuum bagging. As a result of this approach, the geometry of the intake system has been redesigned to result in reduced weight (due to lower material density and lack of welds, hose clamps, and silicon couples), improved charge distribution, and increased torque through a wide RPM range when compared to its traditionally-manufactured aluminum counterpart.

**Keywords:** Fused Deposition Modeling, Intake Manifold, Formula SAE

## 1. CONTEXT: INTAKE MANIFOLD OF A FORMULA SAE VEHICLE

### 1.1 Formula SAE

Formula SAE is an international student design competition organized by the Society of Automotive Engineers (SAE). In this competition, student design teams design, build, and test a small Formula-style race car. The teams, acting as contractors for a fictional manufacturing company, are held to strict rules and design the car as if it were a production item. The car is evaluated via static and dynamic tests. The static evaluations are comprised of an analysis of the car's cost and design as well as a team presentation. The dynamic testing events include skid pad, acceleration, autocross, and endurance trials.

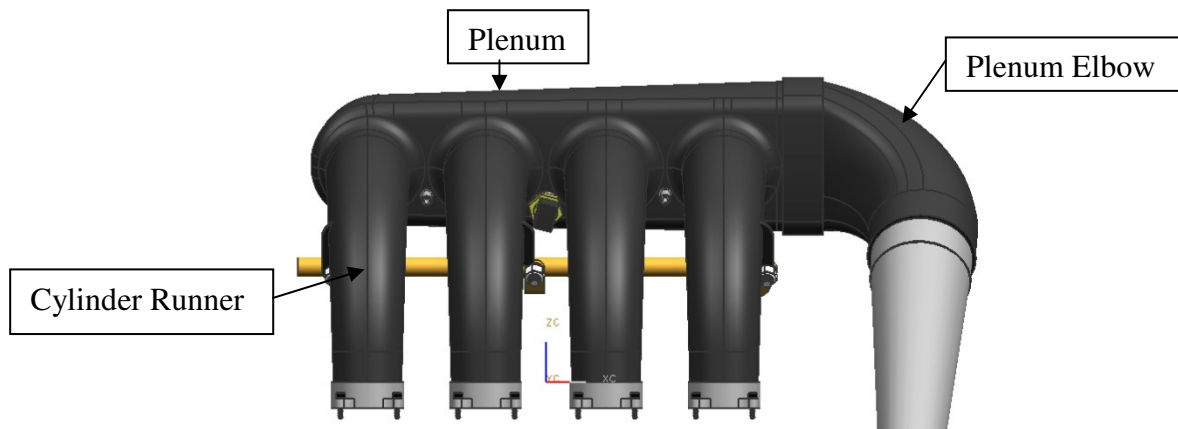
In an effort to create a fuel-efficient, lightweight, cost-effective, and fast automobile, students carefully design each component of their vehicle. Subsystems, ranging from the vehicle frame, to the steering system and the powertrain, are designed by the students, and are frequently manufactured in-house. In this paper, the authors focus on the design and (additive) manufacture of the intake manifold system of the 2009 Virginia Tech Formula SAE car.

### 1.2 Intake Manifold

When designing the engine package for a Formula SAE car, as well as other automotive applications, it is very important to design a quality intake system. The primary function of the intake manifold system (Figure 1) is to deliver combustion air to the engine. Specifically, the primary design goal is to distribute the combustion mixture evenly to each intake port, as doing so improves the engine's ability to efficiently and effectively produce torque and power. The geometric design of the intake system affects the volumetric efficiency of the engine, and thus directly affects the performance of the vehicle.

To realize the primary design goal of providing equivalent amounts of air to each cylinder, there are several objectives to consider when designing an intake manifold:

- Minimize pressure loss, as pressure loss results in a decrease in output power.
- Maintain equal static pressure distribution in the plenum, as this will cause the cylinders to pull the same vacuum, thus leading to even flow in each cylinder.
- Minimize bends and sudden changes in geometry, as these geometric affects can cause pressure loss.
- Maximize air velocity into the cylinder, as this provides a better mixture of fuel and air, which results in better combustion and performance.
- Minimize the mass of the system; a common goal of every subsystem of the vehicle.



**Figure 1.** 3D rendering of the complete intake assembly.

### 1.3 Intake Manifold Manufacture

Traditionally, intake manifold systems are manufactured via bonding multiple aluminum pieces (typically either bent pieces of aluminum tubing or casted aluminum components) together with multiple welds. An example of the aluminum intake designed and manufactured by the 2008 Virginia Tech Formula SAE team is shown in Figure 2. While the use of aluminum provides a structurally sound component with a low mass, this manufacturing technique fundamentally limits the types of manifold geometries that can be created. Due to the inherent geometric limitations imposed by the existing manufacturing process (bending and welding), the team found it difficult to design and fabricate a system in which (i) pressure losses were kept to a minimum and (ii) equal charge was provided to each cylinder.

In this paper a new manufacturing process for fabricating intake manifolds for Formula SAE race cars is presented. Specifically, an intake manifold system is fabricated in a two-step process: (i) a thin-walled ABS core is created via Fused Deposition Modeling (FDM) and then (ii) wrapped with layers of carbon fiber via vacuum bag curing. The combined use of additive manufacturing and composite materials allows for the manufacture of a functional intake with virtually any geometry. This geometric freedom offered by FDM allows a designer to ensure even static pressure distribution throughout the intake and an equal charge to each cylinder. Furthermore, as FDM allows the creation of the entire manifold system as a single piece, the need for welds and other fasteners is eliminated, resulting in an expected reduction in mass.

An overview of the proposed manufacturing process is presented in Section 2. The design and manufacture of an intake manifold using the process is detailed in Section 3. In Section 4, the authors present performance results of the manifold and compare them with manifolds created by more traditional means. Finally, closure is offered in Section 5.



**Figure 2.** Intake manifold composed of welded aluminum pieces.

## **2. ADDITIVE MANUFACTURE OF AN INTAKE MANIFOLD**

### **2.1 Prior Efforts**

Recognizing the geometric flexibility offered by additive manufacturing (AM) techniques, engineers have looked to the technologies as a means of improving the design of intake manifold systems for high-performance automobiles. Various AM technologies have been used to create functional prototypes for testing, to fabricate tooling for creating end-use parts, or to create the end-use parts themselves.

Engineers at Jaguar Cars Ltd. have used laser sintering to prototype intake manifolds for functional testing. The use of these prototyping techniques increased the amount of design iterations while decreasing the financial investment and overall development time for this component [1]. Other engineers have reported the use of laser sintering [2] and solid ground curing [3] to create intake manifold prototypes suitable for testing.

Additionally, AM techniques have been used to create tooling for the manufacture of end-use intake manifolds. In these processes, a pattern of the manifold is created via an AM technology and is then transformed into a functional component either through coating with a carbon fiber composite (followed by removal/dissolution of the pattern) [4,5], or through coating with a ceramic for investment casting with aluminum [6].

Finally, many engineers have looked to AM techniques as a means of creating end-use, functional manifolds. Specifically, several SAE teams from around the globe (Australia [7], United Kingdom [8, 9], United States [10], and Greece [11]) have used laser sintering (LS) to create functional, race-ready manifolds from sintered nylon. To the authors' knowledge, laser sintered nylon is the only reported AM technique that has been used to create an end-use manifold. Nylon is an appropriate material for this application as it is robust enough to handle the high operating temperatures and pressures of the intake manifold.

## 2.2 Fused Deposition Modeling + Composites

Lacking access to a LS machine (and having insufficient funds to hire a service bureau), the student design team looked to other AM technologies as a means of creating an end-use manifold. Having access only to FDM technology (a Stratays Dimension SST), the students were aware that it alone would not be capable of producing an end-use part. The standard ABS material (Stratays, P400 [12]) is neither strong enough to withstand the high pressures found in a turbocharged engine, nor it is heat-resistant enough to its high temperatures. While Stratays does provide high-temperature and high-strength material options (PPSF/PPSU [13], ULTEM 9085 [14]), they can only be processed on Stratays's higher-end machine line, Fortus. Furthermore, parts created via FDM are not airtight due to pores created by poor optimization of material flow, filament/roller slippage, liquefier head motion, and build/fill strategies in the extrusion deposition process [15].

In an effort to address these processing deficiencies, the student team proposed a manufacturing process in which a thin-shelled, FDM-fabricated part is layered with composite material. Specifically, the team chose to apply carbon fiber fabric to the ABS part with a high-temperature resin via a vacuum bagging process. This process alleviates the geometric limitations of traditional manifold manufacturing techniques, and also ensures a light-weight, strong, and heat-resistant component. Additional benefits of this process include:

- While an additional post-processing step is needed in this process when compared to direct fabrication using LS (Section 2.1), the equipment required to fabricate the manifold in the proposed process is much less expensive; LS machines typically cost more than an order of magnitude greater than FDM machines.
- Thanks to the added strength provided by the carbon fiber composite material, the printed manifold shell can be very thin (0.12" thick in this specific application), thus saving printed material and also reducing part mass. Nylon manifolds that are directly fabricated using LS must be printed thicker to have comparable strength.
- The vacuum bagging process cures the resin and hardens the carbon fiber while pulling excess resin out of the part (thus decreasing part weight). Additionally, the vacuum seals the pores present in the FDM-fabricated part as resin is pulled into the structure. Not only does this contribute to part strength, but it increases its resistivity to heat as the high-temperature resin permeates the part's pores.
- Compared to lost core fabrication methods, this process requires fewer layers of carbon fiber as the ABS shell provides structure and strength. Additionally, the proposed process avoids many of the difficulties and frustrations typically encountered in the lost core method. The ABS shell ensures that the designed interior geometry is not compromised by poor composite adhesion and also precludes the need for the removal of a core. Furthermore, should gaps in the composite fabric occur during layup, there is no need to restart the process as the ABS shell provides sufficient strength for operation. Finally, the proposed process does not require the fabrication of a mold in which the pattern is created, reducing manufacturing cost and time.

## 3 INTAKE MANIFOLD DESIGN AND MANUFACTURE

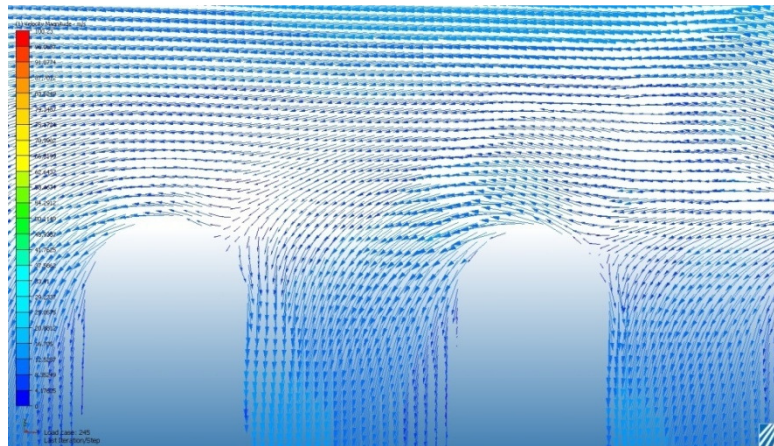
### 3.1 Intake Manifold Design

As the chosen manufacturing process removed prior geometric constraints, the student team was afforded the opportunity to redesign the intake manifold system geometry. In this redesign process, their efforts were directed towards two portions of the system: the length and geometry of the cylinder runners and the geometry of the plenum.

The length and geometry of the cylinder runners were the first components designed. Following the combined use of a dynamometer and computational fluid dynamics (specifically, CFdesign 10.0), a

tapered bent design of approximately 11 inches was selected. This length allows for additional air at the particular RPM range in which the car will operate, thus improving vehicle performance under these certain operating conditions. The team chose the bent design because of the need to fit the 11” runners within the packaging constraints of the vehicle.

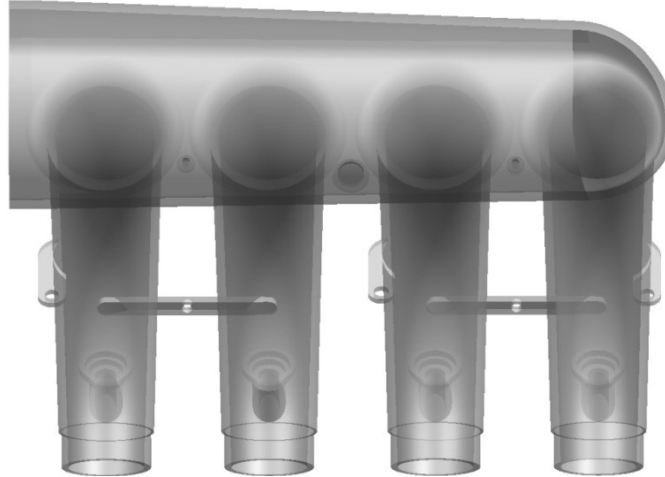
Runner geometry design decisions were dominated by the team’s focus on minimizing pressure losses at the transition from the plenum to the runner. The team discovered that recirculation could be eliminated by creating large inlets to the runners from the plenum and adding a taper to the runners (Figure 3). In addition, the tapered design increases air flow velocity into the cylinders, giving a better mixture of fuel and air to the engine and thus providing better combustion and overall performance.



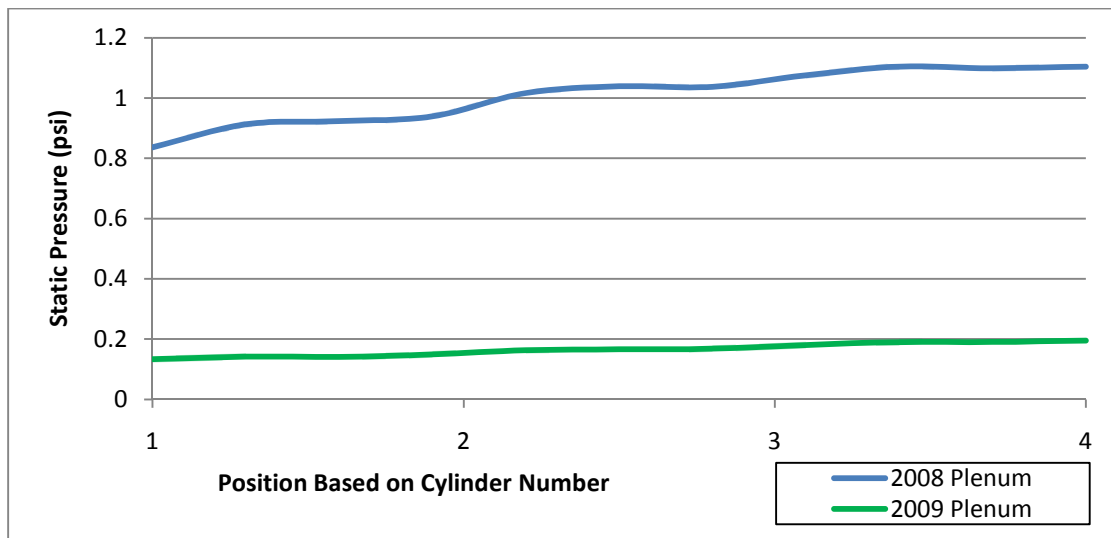
**Figure 3.** Velocity vectors representing air flow as it travels from the plenum to the runners.

In designing the plenum, it is important to achieve an even static pressure as this will cause the cylinders to pull the same vacuum, leading to even flow in each cylinder. In order to achieve this goal, a designer is typically faced with a tradeoff: even static pressures are easily achieved by larger plenum volumes, however this not only becomes difficult to package, it affects throttle response as a larger volume increases the amount of time for the system to reach an equilibrium pressure. With the ability to create a plenum of unlimited geometry, a design was developed that was tapered and could provide an even static pressure. This tapered design offsets the static pressure that is lost due to friction and other factors within the plenum since the taper increases the air velocity as it flows from the entry point to the end. This decrease in size provides gives quick throttle response while keeping an even flow distribution to each cylinder, thus providing increased performance. The final intake manifold system geometry is shown in Figure 4.

The improvement in the static pressure distribution over a similar aluminum design from the 2008 Virginia Tech Formula SAE team can be observed in Figure 5. The 2009 intake system design is similar to that of the 2008 team, featuring the same runner lengths, entry point, plenum volume, and basic layout. The 2008 system was manufactured from aluminum and has a slightly different geometry due to the limitations in using that manufacturing technique (specifically, the inability to taper the runners and the plenum). As seen in the graph, the static pressure drop across the plenum is a fraction of that of the 2008 design. It should also be noted that the static pressure is much lower in the plenum, which is evidence of a smaller pressure drop in the system to this point. With an even static pressure, each cylinder pulls the same vacuum, ensuring that equal amounts of air are provided to each runner, thus increasing performance.



**Figure 4.** Final intake manifold system model.



**Figure 5.** Comparing the static pressure distribution of the 2008 and 2009 plenum designs.

With the interior geometry of the intake system designed, the team turned their attention to the task of detailed design of the component. Specifically, features were added to the manifold model for sensor mounting and mounts for the fuel injector bosses. The ability to integrate these mounts into the geometry reduced the overall manufacturing time, as it eliminated the time needed to manufacture aluminum pieces to be connected to the manifold.

### 3.2 Intake Manifold Manufacture

Following final design reviews and simulations, the CAD model was exported to the .stl format for fabrication on the lab's FDM machine (Stratasys Dimension SST). Due to the constraints of the machine's build volume (8"x8"x10"), the intake system geometry was modified such that the plenum elbow was built as a separate piece. The two pieces were built using the P400 ABS material. Soluble support material (P400-SR) was used to ensure the easy removal of support material from the hollow geometry of the manifold. Once fabricated, the parts were assembled together and bonded using an epoxy (Figure 6).



**Figure 6.** Final assembly of the intake manifold.

With the assembly step complete, the student team proceeded with the application of the composite material onto the manifold. Three layers of carbon fiber fabric were applied to the manifold using a high temperature resin (PTM&W PT2520). This resin was chosen as it is able to survive the high temperatures (~120 F operating, up to 250 F during heat soak) that are endured from the operation of the engine. A vacuum bagging process was used to lay up the fabric onto the manifold. In addition to curing the resin and ensuring a proper fit of the fabric onto the manifold, the vacuum assisted in drawing the high temperature resin into the semi-porous ABS part. In addition to adding some strength, the drawn-in of resin increased the ABS part's resistivity to heat.

The final manifold, featuring the completed composite layup and assembly of all mounts and sensors, is presented in Figure 7. The manifold, as mounted onto the Formula SAE car, is shown in Figure 8.



**Figure 7.** Completed intake system, following the composite layup process and final assembly of sensors and mounts.

The student design team was able to fabricate an end-use intake manifold in just under a week. The plenum and elbow were fabricated in 60 hours using the FDM machine (including support removal in a cleaning solution). An additional 3 days were required for surface and composite work. This manufacturing time is much less than the approximately 2 to 3 weeks that it would take to manufacture similar pieces in an aluminum, as they would require additional time for design, jig creation, and welding.



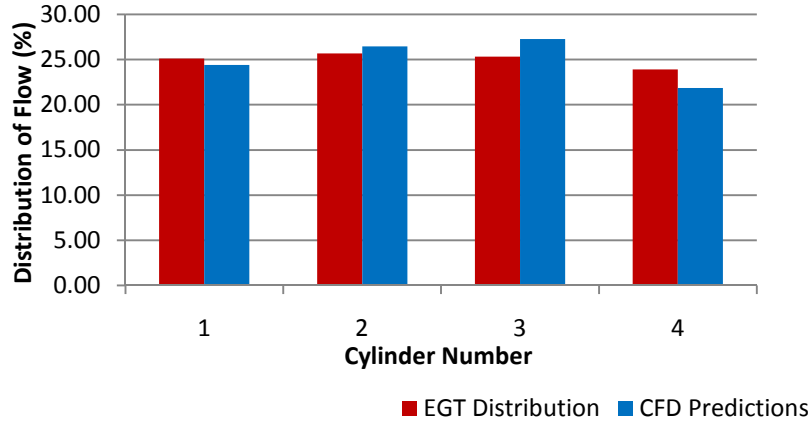
**Figure 8.** The intake system as mounted onto the 2009 Virginia Tech Formula SAE car

#### **4. RESULTS**

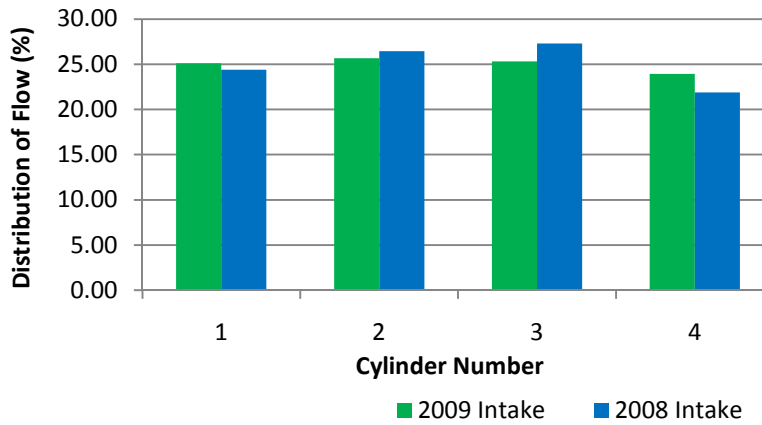
As stated in Section 1.2, the primary goal in the design of an intake manifold system is to improve the engine's ability to efficiently and effectively produce torque and power through the even distribution of the combustion mixture evenly to each intake port. In order to estimate the flow distribution of the system, as well as visualize and analyze the flow to find areas of recirculation and separation that increase pressure drop, simulations were done using CFD. These simulations were then compared with exhaust gas temperature (EGT) data. EGT data can be used to estimate the flow distribution; with more air the EGT data will be high, with more fuel the EGT will be low. The result from these simulations and tests can be seen in Figure 9 and Figure 10. The intake system designs from the 2009 and 2008 teams are compared in Figure 10.

In Figure 10 it is evident that the design changes described in Section 3.1 have improved the flow distribution across the cylinders. These part-level improvements have transferred to improvements at the overall engine-level. Specifically, due to the new design, the engine package for 2009 car was able to achieve more torque than that of 2008. The differences in the torque curves of 2008 to 2009 as well as that of the most powerful natural aspirated (NA) engine at the 2007 competition can be seen in Figure 11. Even though the engine package for 2009 had a lower peak torque, the torque curve is much more consistent over a longer range of RPMs, improving the drivability of the vehicle - a major design goal for the 2009 student team. The 2009 turbocharged engine also produced more torque throughout the complete RPM range over the naturally aspirated engine. The 2009 engine maintained a higher torque than the 2007 NA engine for a range of 6000 RPM compared to a 4700 RPM range for the 2008 engine. These improvements over previous designs are due largely to the new manufacturing process of the intake system, which enabled the design of a manifold that provided a more even flow distribution to each cylinder and a reduction of pressure losses.

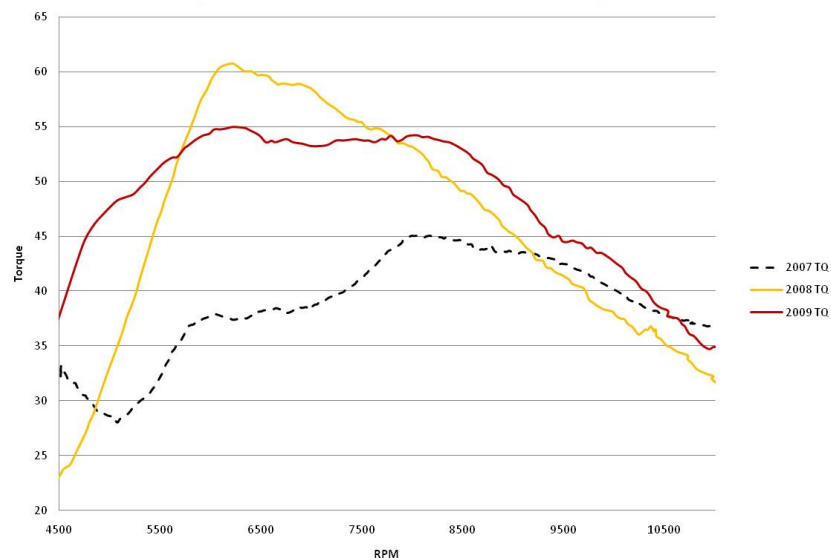




**Figure 9.** Flow distribution into each cylinder based on CFD and EGT data.



**Figure 10.** Comparing the flow distribution of the 2009 and 2008 intake systems.



**Figure 11.** Comparing the torque of the 2009 turbocharged engine, the 2008 turbocharged engine, and the most powerful NA engine at the 2007 competition.

## 5. CLOSURE

In this paper, the authors present a manufacturing process used to create an intake manifold for a Formula SAE car. Specifically, an intake manifold shell is first printed using Fused Deposition Modeling; composite material is then applied to the shell with a high temperature resin and a vacuum bagging process. The use of FDM provided geometric flexibility in the design of the manifold, while the use of composite material and high-temperature resin ensured that the system would have sufficient strength and heat-resistivity to survive the operating environment of the turbo-charged engine.

The use of FDM provided the student design team the freedom to create a unique intake geometry that featured a tapered plenum and tapered runners. These geometric features provided an even static pressure throughout the system, an equal charge to each cylinder, reduced pressure loss, and an increased air velocity into the cylinders - key goals in manifold design. The use of the additive manufacturing technology ensured the creation of a system free from sudden geometry changes, which reduce flow separation and increase pressure loss.

The manifold that resulted from the process greatly improved the performance of the Formula SAE engine, as compared to a similar aluminum design. The new design provided an increase in torque over an extended RPM range as the manufacturing process provided the ability to create a complex geometry that provided equal air to each cylinder and reduced total pressure drop. Additionally, relative to the previous design, the total weight of the system was reduced from 2.875 lbm to 2.24 lbm (a 22% decrease).

## 6. REFERENCES

1. Jackson, S., 2008, "From Rapid Prototyping to Mass Customization," *Industrial Laser Solutions for Manufacturing*, [http://www.industrial-lasers.com/articles/article\\_display.html?id=333159](http://www.industrial-lasers.com/articles/article_display.html?id=333159), accessed July 2009.
2. Gebhardt, A., 2003, *Rapid Prototyping*, Hanser.
3. Abbott, P., 1998, "Rapid Prototyping," *Assembly Automation*, Vol. 18, Iss. 1, Mini-feature.
4. Dore, S., P. Lavallee, 1997, "Design and Fabrication of Intake Manifold for Formula SAE (Society of Automotive Engineers) Race Car," *Rapid Product Development Technologies*, P. Boulanger (ed.), pp. 187-197.
5. "Hi-Tech Hot Rod is the Ultimate Learning Lab," 2005, *ScienceDaily*, <http://www.sciencedaily.com/releases/2005/01/050125085013.htm>, accessed July 2009.
6. "Rapid Prototyping System Helps Students Create a Formula Car," January 1998, *Modern Machine Shop*, <http://www.mmsonline.com/articles/rapid-prototyping-system-helps-students-create-a-formula-car.aspx>, accessed July 2009.
7. Envizage, "QUT Motorsport - SLS Rapid Manufactures," *Envizage Case Study*, [http://www.envizage.com.au/case\\_studies/case\\_study\\_14.php](http://www.envizage.com.au/case_studies/case_study_14.php), accessed July 2009.
8. 3T RPD Ltd., "Formula Student achieves top marks with 3T," *3T RPD Ltd. Case Studies*, <http://www.3trpd.co.uk/case-studies/formula-student.htm>, accessed July 2009.
9. Hopkinson, N., R. J. M. Hague, P. M. Dickens, 2006, *Rapid Manufacturing: An Industrial Revolution for the Digital Age*, John Wiley & Sons Ltd., West Sussex, England.
10. 3D Systems, 2009, "University Race Team Benefits from Sintered Engine System," *A 3D Systems Success Story*, [http://www.3dsystems.com/products/datafiles/success\\_stories/OSU\\_SLS\\_Case\\_Study.pdf](http://www.3dsystems.com/products/datafiles/success_stories/OSU_SLS_Case_Study.pdf), accessed July 2009.

11. Mihailidis, A., Z. Samaras, I. Nerantzis, G. Fontaras, G. Karaoglanidis, 2009, "The Design of a Formula Student Race Car; A Case Study," Proceedings of the Institution of Mechanical Engineers. Part D, Journal of Automobile Engineering, Vol. 223, Iss. 6, pp. 805-818.
12. Stratasys, 2009, "P400 ABS Material Specification Sheet," Redeye, [http://redeyeondemand.com/Downloads/MSpec\\_ABS.pdf](http://redeyeondemand.com/Downloads/MSpec_ABS.pdf), accessed July 2009.
13. Stratasys, 2009, "Polyphenylsulfone Specification Sheet," Redeye, [http://redeyeondemand.com/Downloads/MSpec\\_PPSF.pdf](http://redeyeondemand.com/Downloads/MSpec_PPSF.pdf), accessed July 2009.
14. Stratasys, 2009, "ULTEM 9085 Specification Sheet," Fortus, [http://www.fortus.com/uploadedFiles/North\\_America/Materials/Files-Materials/MS-ULTEM9085-FORTUS-0109.pdf](http://www.fortus.com/uploadedFiles/North_America/Materials/Files-Materials/MS-ULTEM9085-FORTUS-0109.pdf), accessed July 2009.
15. Agarwala, M. K., V. R. Jamalabad, N. A. Langrana, A. Safari, P. J. Whalen and S. C. Danforth, 1996, "Structural Quality of Parts Processed by Fused Deposition," *Rapid Prototyping Journal*, Vol. 2, No. 4, pp. 4-19.