

DEVELOPMENT OF POWDER BED FUSION ADDITIVE MANUFACTURING TEST BED FOR ENHANCED REAL-TIME PROCESS CONTROL

M. L. Vlasea*, B. Lane*, F. Lopez*, S. Mekhontsev*, A. Donmez*

* National Institute of Standards and Technology, Gaithersburg, MD 20899¹

REVIEWED

Abstract

Laser powder bed fusion (PBF) is emerging as the most popular additive manufacturing (AM) method for producing metallic components based on the flexibility in accommodating a wide range of materials with resulting mechanical properties similar to bulk machined counterparts, as well as based on in-class fabrication speed. Although this approach is advantageous, the current limitations in achieving predictable and repeatable material and structural properties, geometric and surface roughness characteristics, and the occurrence of deformations due to residual stresses results in significant variations in part quality and reliability. Therefore, a better understanding and control of PBF AM processes is needed. The National Institute of Standards and Technology (NIST) is developing a testbed to assess in-process and process-intermittent metrology methods and real-time process control algorithms, and to establish foundations for traceable radiance-based temperature measurements that support high-fidelity process modeling efforts. This paper will discuss functional requirements and design solutions to meet these distinct objectives.

1 Introduction

Laser powder bed fusion (PBF) additive manufacturing (AM) processes, are highly versatile manufacturing strategies, demonstrating a range of competitive advantages over conventional manufacturing in terms of enabling the production of customized parts with intricate internal lattice features and complex external geometries [1,2] without the use of dedicated tooling [1], essentially reducing the time between digital design and fabrication [3]. In addition to the customization of geometrical features, laser PBF processes have the potential of producing lightweight or weight-optimized lattice structures with suitable mechanical properties [4] and multi-material composition [2], with minimal material loss. Although the parts produced using laser-based AM approaches tend to have embedded pores, their densities can reach almost 100%, having mechanical properties equaling and at times exceeding those of conventionally manufactured counterparts [1,5,6]. In the new generation of digital design considerations, a breakeven point exists where the complexity, weight optimization, and low production demands of parts favor AM approaches [6], with industry contenders ranging from the medical field, to aerospace applications. The benefits of laser-based PBF have sparked interest among the research community and industry, with an increased focus on strategies to overcome some of the existing challenges related to part quality, consistency, and repeatability [7].

¹ Official contribution of the National Institute of Standards and Technology (NIST); not subject to copyright in the United States. The full descriptions of the procedures used in this paper may require the identification of certain commercial products. The inclusion of such information should in no way be construed as indicating that such products are endorsed by NIST or are recommended by NIST or that they are necessarily the best materials, instruments, software or suppliers for described purposes.

According to literature in the field, PBF processes have a high degree of sensitivity to disturbances and input process parameters such as laser power, laser scanning path, and scan speed. The vast number of controllable and predefined process parameters as summarized by Mani et al. [7] have a complex influence over the transient thermal behavior of the melt pool, often resulting in unexpected defects (pores) [8], high surface roughness [3,7], thermal cracking and delamination [9], unintended anisotropic mechanical and physical properties [1,3,10], as well as anisotropic shrinkage [11]. Pores can be traced back to the high temperature input associated with laser AM that may cause material vaporization and spatter during the dynamic laser-substrate interaction [3]. Undesirable porous regions can also be associated with the so-called balling phenomenon, which can occur due to poor wettability of the previous layer resulting in molten material not binding to the underlying substrate. This type of process defect has been linked to insufficient local laser power or high scan speeds [10]. Surface roughness and surface defects can become severe, especially in so-called overhang zones, where sections of the in-process layer are supported by powder. In these areas, the laser-powder interaction causes local overheating due to poor heat conduction and dissipation, resulting in an over-sized melt pool geometry [12]. Furthermore, high cooling rates and repeated thermal loading caused by latent heat of fusion, adjacent laser scanning paths within the layer, as well as heat imparted from subsequent layers, have a significant effect on local transient temperature distributions and temperature gradients, triggering rapid heating, melting, and solidification cycles [2]. These effects cause high residual stresses in the part [13,14] resulting in curling of surfaces, microstructure heterogeneity [15], and dimensional deviations of the final part [11,16]. It is important to reduce thermal stresses, as they cause premature part failure and defects [12].

The vast number of process parameters interacting to create a dynamic melt pool environment increase the complexity level of laser PBF manufacturing approaches. Current strategies for determining optimal process parameters of emerging materials or refinements for existing materials still rely on expensive and time-consuming trial and error iterations [7,9,17]. To minimize the need for such iterations, researchers are working on developing high fidelity physics-based models of AM processes to narrow down the input parameter range. However, these models rely on accurate input material properties such as diffusivity, reflectance, and emittance of materials in multiple states of aggregation (powder, liquid, solid), which are currently unavailable [18,19]. These models also require traceable process measurements for fine-tuning and validation. In commercially available machines, once appropriate process parameters have been identified, they are typically kept constant, often leading to part defects and process instability as the process becomes more sensitive to disturbances [1,20]. In order for laser-based AM technologies to become an integral part of mainstream manufacturing, the produced parts have to adhere to stringent quality standards, with repeatable and reliable characteristics [4,5]. To achieve this goal, it is important to advance the science behind developing appropriate metrology strategies to aid in refining our understanding of the relationship and relative sensitivities between input process parameters, process signatures, and product qualities [7], and integrate the knowledge gained into effective quality monitoring and control strategies [5].

2 Measurement organizational structure for controls implementation

While there have been multiple research efforts and even commercial implementation in sensing, monitoring, and controlling metal-based AM processes, there is still significant research required before they can become commonplace on commercial AM systems. In the literature, most papers either investigated the correlations between process input parameters and product qualities [20,21] or exclusively focused on defining relationships between process parameters and melt pool characteristics as process signatures [10,12,13,18], with some works concentrating on in-situ process control strategies [1,3,5,15,17,19,22]. In their review work, Mani et al. [7] reviewed metrology approaches, as well identified the correlations between process parameters, process signatures, and product qualities with a direct relevance to developing strategies for in-situ monitoring and control. To further establish the foundations for AM process control, the process parameters, process signatures, and product quality were sub-categorized according to the abilities to be measured and/or influenced as control parameters in the process as shown in Figure 1 [7]. Prior to this work, process parameters and signatures relations from literature had not yet been logically related to product quality in a broader, general fashion.

Process Parameter Space	Signature Parameter Space	Product Qualities Parameter Space
<p>Controllable</p> <ol style="list-style-type: none"> 1. Laser scan speed 2. Laser power 3. Laser beam diameter 4. Laser scan path 5. Layer thickness variation 6. Inert gas flow <p>Predefined</p> <ol style="list-style-type: none"> 7. Powder size distribution 8. Powder packing density 9. Layer thickness 10. Absorptivity 11. Reflectance 12. Build plate properties 	<p>Melt Pool</p> <ol style="list-style-type: none"> 13. Temperature (maximum temperature, temperature gradient) 14. Geometry (width, length, depth, area) 15. Plume characteristics <p>Track</p> <ol style="list-style-type: none"> 16. Geometric irregularity 17. Un-melted particles 18. Shrinkage 19. Residual stress 20. Microstructure (crystal, phase) 21. Voids <p>Layer</p> <ol style="list-style-type: none"> 22. Geometric irregularity 23. Un-melted particles 24. Shrinkage 25. Residual stress 26. Microstructure (crystal, phase) 27. Voids 28. Defects 	<p>Geometric</p> <ol style="list-style-type: none"> 29. Size dimensional deviations 30. Form dimensional deviations <p>Mechanical</p> <ol style="list-style-type: none"> 31. Strength 32. Hardness 33. Toughness 34. Fatigue resistance <p>Physical</p> <ol style="list-style-type: none"> 35. Residual stress 36. Surface toughness 37. Porosity 38. Defects

Figure 1 The hierarchy of process parameters, process signatures, and product qualities as identified by Mani et al. [7]

This current work focuses on providing the relationship map between measurand, measurement method, and control strategies in laser PBF through references to current research efforts, as well

as outlining limitations and potential opportunities in advancing intelligent controls in AM. An organizational structure for control strategies, presented in context with the previously established hierarchy of parameters [7] is proposed as seen in Figure 2. In this figure, the measurand is defined as the parameter information acquired through appropriate measurement technologies and processed into a suitable data stream for post-process analysis, in-situ process monitoring, and feedback process control. As part of control strategies, four types of approaches have been identified and will be discussed in further detail: pre-processing for predictive control, in-situ defect or fault detection and handling, in-situ continuous feedback control, and signature-derived control through plant models or simulations. Another category of feedback-dependent strategy closely correlated with process control outcomes is part qualification through in-process monitoring and analysis, which is an emerging field in AM part certification and quality control [18]. This type of technique takes advantage of the layer-by-layer manufacturing approach to perform continuous process-signature analysis and layer-intermittent inspection of layer qualities.

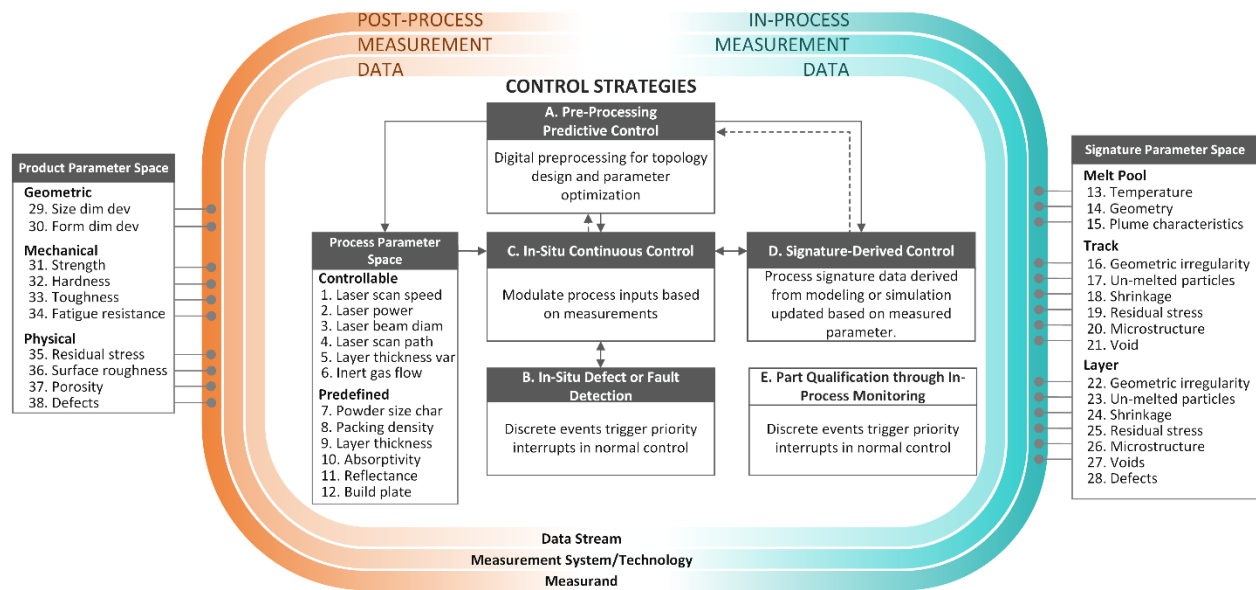

Figure 2 Measurement organizational structure in the context of possible controls strategies for PBF AM

2.1 Pre-processing for predictive control

Presently, there is an active interest in refining AM processes for fabricating products with heterogeneous or functionally graded structural, compositional, and mechanical properties with applications in industrial, aerospace, and biomedical fields [23], as well as a continued interest in refining AM processes for producing products with consistent and repeatable part qualities. In this context, pre-processing for predictive control can have a multi-layered architecture that first considers (a) digital pre-processing for three-dimensional topology design, and subsequently considers (b) an input parameter optimization stage to achieve the desired design configurations.

The control strategy for digital pre-processing of three dimensional parts for compositional and topological optimization, focuses on the digital design and characterization using modeling

approaches. Modelling should consider discrete and stacked lattice structures composed of multi-material and/or multi-structural cellular features to investigate configurations that can meet design criteria as well as compute a range of initial input process parameters for the AM process. Previous modeling work has typically focused on balancing the tradeoff between structural topology for lightweight design and resulting mechanical properties [24,25], as well as modeling the relationship between process parameters and resulting thermal behavior to infer refinements of the input parameter space based on trends to avoid high thermal loading and associated potential defects [2,11,14,26–28]. To the authors' knowledge, no work has been done on merging structural topology optimization and thermal modeling into a coherent digital pre-processing algorithm at the 3D scale.

Secondly, there is an opportunity to investigate optimization strategies that can enable further refinement of input process parameters by taking into account experimentally measured process parameters, process signatures, and product quality data from previously manufactured batches of similar products to continuously improve geometric shape fidelity and account for drifts in machine performance and raw material batch variation. For example, one strategy could be to continuously monitor the relationship between the designed 3D digital model, the 3D in-line reconstructed model (from thermal, acoustic, layer imaging, laser profilometry, contact image sensing, infrared detection data), and the 3D generated scan of the final part to generate pre-processing predictive control strategies for better part quality, process speed, and reliability. One example is the work done by Ning et al. [11], where an experimentally-derived model was developed to correlate 2D in-layer geometric shape to shrinkage, and furthermore, the model was used in a feedback scan compensation algorithm to pre-compute laser scan-speed compensation factors resulting in increased dimensional accuracy of subsequent parts.

2.2 In-situ defect or fault detection and handling

In these schemes, the controller responds to defects or faults by triggering discrete events that interrupt normal control routines and activate a corrective action to avoid process instability which may lead to catastrophic failure of the manufactured part. While some errors or faults can be compensated via continuous feedback control, some errors require separate error handling routines, which are the focus of this section. Overlaps between the two control strategies should exist, as they are complementary and share the same measurement parameter space. In this context, process errors can be related to non-uniform powder layer spread due to damage of the re-coating mechanism [5], collisions between the re-coater and super-elevations [13], powder exhaustion [5,18], or contaminants in the powder substrate. Process errors can also be related to defects in the track or layer such as unintended porosities and high surface roughness due to unmelted particles, material ejection during melting, and balling effects [3,9,29], as well as excessive shrinkage and curling due to residual stress [11,13,14]. Other errors relate to machine parameters such as laser beam delivery and chamber environment [19], and can be monitored and controlled such that the process is interrupted until normal operation can resume.

Research focusing on the quality of powder spread has generally made use of imaging systems such as a monochrome charge-coupled device (CCD) camera and dark field illumination with an angled viewpoint to highlight surface powder disturbances for qualitative measurements [20], as

well as for quantitative evaluation of powder profile [5] to evaluate re-coater blade extent and location of damage. One possible controller corrective action is identification of areas of inconsistent powder spreading before the deposition process begins and re-positioning the part at a more convenient location in the build space. If the powder spread error occurs during the build phase, attempting to re-spread a new layer or dynamically adjusting or replacing the re-coater blade could also be feasible. When detecting process errors related to pores or part surface roughness, research has mainly focused on thermal process signature measurements and the correlation between abnormal measurements and defect outcome using either photodiode [5] or pyrometer [10] measurements, or microbolometer detectors [18]. For instance, Krauss et al. [18] have focused on detecting porous defects using thermal monitoring via an uncooled microbolometer detector by considering both spatial and temporal signatures of the heat affected zone to detect pores up to 100 μm in size. Craeghs et al. [5] have coupled a photodiode signal with melt pool area measurements obtained from using a complementary metal-oxide semiconductor (CMOS) camera to detect abnormal trends which can be correlated to porosities, surface roughness errors, layer thickness inconsistency errors, and gradual part quality deterioration. Most relevant research in this area focuses on defect, error, or fault detection, evaluating trends for offline refinement of input parameters, with little work done on in-line error detection coupled with corrective actions.

2.3 In-situ continuous feedback control

Feedback process control schemes to-date allow for controllable process input parameters to be continuously modulated based on feedback from measurable process signatures or product qualities via decisions from a controller algorithm [19]. Additional control loops should be implemented to monitor the input process parameters to ensure that the equipment is actually running according to specified command input signals.

The first implementations of feedback control in metal-based AM originated in the laser surface alloying and laser cladding industries. Römer et al. [30] proposed a temperature and melt pool controller for the laser alloying process fed with thermographic measurements. Similar approaches were followed for the laser cladding process by controlling clad height [31,32], melt pool temperature [15,33], or melt pool width [34]. Feedback control has also been used in direct energy deposition (DED) processes, to control melt pool temperature [35,36] or melt pool area [37] and similarly in SLM, melt pool parameters [1,5,17,22] and plasma plume measurements [3]. All of these approaches used thermal measurements obtained with CCD, CMOS, or infrared (IR) cameras. There is a consensus in the need for thermal measurements for feedback control and the utilization of proportional-integral-derivative (PID) controllers is a popular approach [15,21,22,30–35,37], as well as other emerging implementation strategies such as model predictive control [36]. The design of said controllers is often based on heuristics [15,35,37,38], or on plant models obtained through system identification [12,21,30–33,36], and rarely on physics-based models [34]. The development of such high fidelity physics-based models of AM processes rely on accurate measurements of input material properties such as diffusivity, reflectance, and emittance of materials in multiple states of aggregation (powder, liquid, solid), measurements which are difficult to obtain, and are the incentive behind the development of a new AM metrology test bed at NIST.

Despite all the work in continuous feedback control, there is still room for improvement, especially in thermal metrology and controller design. Previous implementations of thermal imaging often oversimplified calibration, ignored camera saturation, or assumed constant surface emissivity. All of these factors may result in erroneous measurements that insert error in the feedback control loop. Also, system identification approaches require extensive testing to identify the dominant dynamics of the plant. Results are often not extendable to other materials, or geometries, limiting their applicability.

2.4 Signature-derived control through plant models or simulations

Signature-derived control schemes rely on results (estimations) derived from process modeling or simulation algorithms that use in-situ feedback signals as inputs to compute or infer immeasurable quantities. These derived quantities (or estimations) can then be used as further inputs to a control algorithm. This implies that simulations may run in parallel with the controller or that process maps and lookup tables are dynamically accessible. In general, estimation is often ignored in feedback control for metal-based AM. This may be attributed to two factors: 1) the lack of appropriate models that map measurable process parameters to immeasurable process signatures, and 2) the fast dynamics of the processes that force all measurements to be gathered and processed at very high sampling frequencies. In the literature, the preferred trend is to find a way to measure the quantity of interest directly rather than to use available measurements to infer it [19]. As an example, the work done by Aggarangsi et al. [8], where a thermomechanical finite element analysis (FEA) model was developed to estimate residual stresses within a thin wall and process maps were devised to correlate stress, melt pool depth, and laser power, could be further enhanced as signature-derived control. Another example is the model-based controller developed by Devesse et al. [34], where temperature measurements were used as feedback to estimate melt pool size and to ultimately control the laser power. Other developed models based on experimentally derived parameters [9,39] show promise in this area. Although often ignored, there is a wealth of opportunity in developing estimation methods or models for feedback control.

2.5 Part qualification through process monitoring and analysis

These control schemes enable automated qualification of the final part after the build is complete. The controller decision is the culmination of multiple measurements, or a single measurement at the end of the build, and quantifies product quality form in terms of geometry, material structure, surface finish, or porosity characteristics. There are currently no recognized industrial or research solutions that address this need. In their report, Mani et al. [7] have identified a comprehensive list of in-process layer geometry measurements [13,40] and post-processing measurements of part quality applicable to dimensional accuracy [41], surface quality [42], mechanical properties [42,43], residual stress [44], porosity and density [45], and fatigue [46], that can help in part qualification. These product qualities have been studied by various research groups and correlated to input process parameters or with process signatures. However the development of heuristic in-process or process-intermittent metrology approaches for part qualification has not been implemented and can prove to be an interesting research opportunity.

3 Proposed additive manufacturing metrology test bed

In recognition of the possible opportunities in furthering research into monitoring, metrology, and process control for laser powder bed fusion, NIST is developing a SLS AM testbed with a dual purpose: (1) to assess in-process and process-intermittent metrology methods and real-time process control algorithms aimed to enhance process repeatability, reliability, and part quality, and (2) to establish foundations for traceable radiance-based temperature measurements that support high-fidelity process modeling and model validation efforts, as well as to study methods for real-time thermometry in the production environment. It is anticipated that development of this testbed will contribute to the development of the next generation of AM mechatronic systems that would empower AM for widespread use for cost-effective functional part production. This section will introduce the functional requirements and some of the design solutions considered thus far to meet these two distinct objectives.

3.1 *General functional requirements and design solutions*

The system has been designed to operate in two modes, so-called Build Mode, used to meet the demands of purpose (1) as stated above, and Radiance-based Metrology Mode, to address purpose (2). In Build Mode, the system should be capable of basic part production functionality, where the re-coater arm is able to spread powder from a feed bed area to a build bed, and a laser system directs the beam to the appropriate location. The build area has a temperature-controlled heated plate, with a temperature target of 80 °C, with the capability of adding a high temperature build chamber-insert capable of heating the build plate and chamber walls to at least 250 °C. The build plate can be manually adjusted to correct for tilt in the direction of powder spreading using a screw-activated pivoting kinematic clamp assembly. The re-coater arm allows for adjustment of the recoating blade tilt along the direction perpendicular to the direction of spread. Table 1 summarizes the design requirements for the build and feed compartments. The Build Mode design should also accommodate for the appropriate sensors and instrumentation used to support in-process and process-intermittent metrology, as well as development of control strategies.

Table 1 Design functional requirements for Build Mode

Component	Effective Specifications
Feed bed – height	180 mm
Build bed – height (low temperature)	90 mm
Build bed – height (high temperature)	25-30 mm
Feed bed – size	150 x 150 mm
Build bed – size (low temperature)	150 x 250 mm
Build bed – size (high temperature)	Φ100 mm
Temperature build bed (large chamber)	80 °C (175 °F) bottom
Temperature build bed (small chamber)	250 °C (482 °F) (chamber)
Build bed tilt alignment screw (x-axis)	1.3 deg/rev
Laser power, continuous	500 Watt
Materials	metal/alloy powders

In Radiance-based Metrology Mode, the laser beam has to interact not only with the powder substrate in the build bed, but also with a range of calibration standards: an IR standard source, visible near IR (VIS-NIR) standard source, as well as with a VIS-NIR reflectance standard, with reflectometry measurements taken under an integrative reflectometer dome. To achieve this task, the entire powder bed assembly was designed to be able to translate with high accuracy between various build and metrology positions. The powder assembly system, along with the actuation mechanisms is referred to as the powder bed carriage. The integrative dome is designed to be retractable by allowing reciprocating motion, moving in and out of the laser path on command.

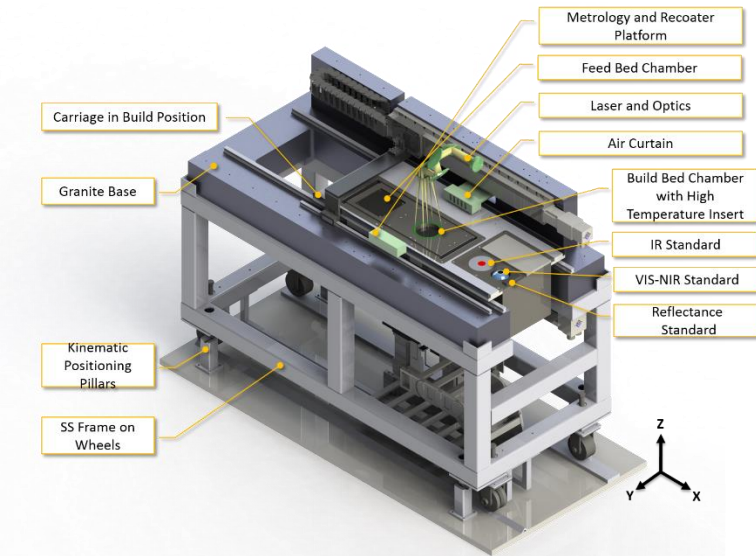

(a)

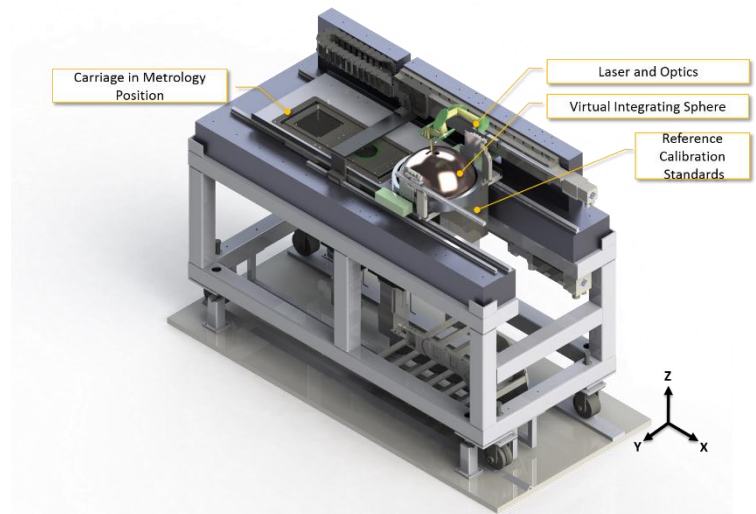

(b)

Figure 3 (a) Conceptual design shown in Build Mode, where the build area is aligned with the air blade, and the in-process and process-intermittent metrology methods and real-time process control algorithms can be tested. (b) Conceptual design shown in Radiance-based Metrology Mode, with the carriage moved such that the IR standard source is in position, under the metrology integrated dome.

3.2 Proposed metrology instrumentation for monitoring and control opportunities

The system is currently transitioning from the design stage, to implementation. The metrology instrumentation will include strategies for in-line coaxial continuous monitoring for thermal measurements using a single point high-speed filtered photodetector, as well as a coaxial IR imaging system to detect melt pool geometry. Vision-based systems will be integrated to monitor continuously or intermittently the powder spread quality, as well as estimating the layer product qualities such as geometry, pores, deformations due to residual stress, and general part photogrammetry. A modular re-coating arm will be integrated in the system to allow for testing of different sensing strategies including acoustic, as well as non-contact measurements such as laser profilometry, contact image sensing, and 2D laser displacement sensing. Process signature characterization will include strategies for radiometric measurements, emissivity measurements, and traceable thermal measurements, which will be used in improving and validating of modeling strategies. Other sensing technologies are currently being explored.

From a metrology standpoint, there is a recognized need to further the development of relationships between process parameters, process signatures, and part qualities, as well as exploring the sensitivities of those relationships through experiment and simulation [7], which will be one of the important goals of the newly developed AM test bed. Furthermore, there are opportunities in developing measurement strategies for a range of other less explored process signatures, such as laser ablation plume size, as well as spectral measurements in the process zone. An important consideration will be given to understanding the measurement uncertainty, as well as analysis of measurement error and traceability. The first research phase using the newly developed test bed will focus on these metrology-related goals.

The control strategy map illustrated in Figure 2 provides a large-scale outline of the possible controls approaches for powder bed fusion AM. Currently, control strategies rely mainly on correlations between melt pool geometry and temperature. The proposed schemes will focus on establishing a multi-control architecture, with the potential of encompassing pre-processing strategies, error detection and handling, continuous feedback control, and signature-derived control. These approaches will be explored in future work.

4 Conclusions

This work has focused on outlining the advantages and challenges of laser PBF AM, as well as understanding the need for developing a new generation of control strategies. An organizational structure for possible controls strategies has been proposed, to encompass pre-processing predictive control, in-situ defect or fault detection and handling, in-situ continuous feedback control, and signature-derived control through plant models or simulations. In addition, part qualification through in-process monitoring and analysis has been discussed, which is an emerging field in AM part certification and quality control. The PBF AM testbed being developed at NIST aims to advance the current state of the art of metrology, monitoring, and control in the field. The system has been introduced in this work by describing the general functional requirements and design solutions, and the proposed vision for metrology and control.

References

- [1] Craeghs T, Bechmann F, Berumen S, Kruth J-P. Feedback control of Layerwise Laser Melting using optical sensors. *Phys Procedia* 2010;5:505–14. doi:10.1016/j.phpro.2010.08.078.
- [2] Raghavan A, Wei HL, Palmer TA, DebRoy T. Heat transfer and fluid flow in additive manufacturing. *J Laser Appl* 2013;25:052006. doi:10.2351/1.4817788.
- [3] Mumtaz KA, Hopkinson N. Selective Laser Melting of thin wall parts using pulse shaping. *J Mater Process Technol* 2010;210:279–87. doi:10.1016/j.jmatprotec.2009.09.011.
- [4] Lott P, Schleifenbaum H, Meiners W, Wissenbach K, Hinke C, Bültmann J. Design of an Optical system for the In Situ Process Monitoring of Selective Laser Melting (SLM). *Phys Procedia* 2011;12:683–90. doi:10.1016/j.phpro.2011.03.085.
- [5] Craeghs T, Clijsters S, Yasa E, Kruth J-P. Online quality control of selective laser melting. *Proc. Solid Free. Fabr. Symp. Austin TX, 2011*, p. 212–26.
- [6] Merkt S, Hinke C, Schleifenbaum H, Voswinckel H. Geometric complexity analysis in an integrative technology evaluation model (ITEM) for selective laser melting (SLM). *South Afr J Ind Eng* 2012;23:97–105. doi:DOI: 10.7166/23-2-333.
- [7] Mani M, Lane B, Donmez A, Feng S, Moylan S, Feserman R. Measurement Science Needs for Real-time Control of Additive Manufacturing Powder Bed Fusion Processes. National Institute of Standards and Technology; 2015.
- [8] Aggarangsi P, Beuth JL, Griffith ML. Melt pool size and stress control for laser-based deposition near a free edge. *Solid Free. Fabr. Proc., Citeseer; 2003*, p. 196–207.
- [9] Körner C, Attar E, Heintz P. Mesoscopic simulation of selective beam melting processes. *J Mater Process Technol* 2011;211:978–87. doi:10.1016/j.jmatprotec.2010.12.016.
- [10] Islam M, Purtonen T, Piili H, Salminen A, Nyrhilä O. Temperature Profile and Imaging Analysis of Laser Additive Manufacturing of Stainless Steel. *Phys Procedia* 2013;41:835–42. doi:10.1016/j.phpro.2013.03.156.
- [11] Ning Y, Wong Y, Fuh JY, Loh HT. An approach to minimize build errors in direct metal laser sintering. *Autom Sci Eng IEEE Trans On* 2006;3:73–80.
- [12] Craeghs T, Clijsters S, Kruth J-P, Bechmann F, Ebert M-C. Detection of Process Failures in Layerwise Laser Melting with Optical Process Monitoring. *Laser Assist Net Shape Eng 7 LANE* 2012 2012;39:753–9. doi:10.1016/j.phpro.2012.10.097.
- [13] Kleszczynski S, Jacobsmullen J, Sehr JT, Witt G. Error Detection in Laser Beam Melting Systems by High Resolution Imaging. *Solid Free. Fabr. Proc., Austin, TX: 2012*.
- [14] Zhang Y, Faghri A, Buckley CW, Bergman TL. Three-dimensional sintering of two-component metal powders with stationary and moving laser beams. *J Heat Transf* 2000;122:150–8.
- [15] Bi G, Gasser A, Wissenbach K, Drenker A, Poprawe R. Characterization of the process control for the direct laser metallic powder deposition. *Surf Coat Technol* 2006;201:2676–83. doi:10.1016/j.surfcoat.2006.05.006.
- [16] Krol TA, Seidel C, Schilp J, Hofmann M, Gan W, Zaeh MF. Verification of Structural Simulation Results of Metal-based Additive Manufacturing by Means of Neutron Diffraction. *Phys Procedia* 2013;41:849–57. doi:10.1016/j.phpro.2013.03.158.
- [17] Kruth J, Mercelis P, Van Vaerenbergh J, Craeghs T. Feedback control of selective laser melting. *Proc. 3rd Int. Conf. Adv. Res. Virtual Rapid Prototyp. Leir. Port. Sept, Citeseer; 2007*, p. 24–9.

- [18] Krauss H, Eschey C, Zaeh MF. Thermography for Monitoring the Selective Laser Melting Process. *Proc Solid Free Fabr Symp* 2012;999–1014.
- [19] Reutzel EW, Nassar AR. A survey of sensing and control systems for machine and process monitoring of directed-energy, metal-based additive manufacturing. *Rapid Prototyp J* 2015;21:159–67. doi:10.1108/RPJ-12-2014-0177.
- [20] Kleszczynski A, Jacobsmühlen J, Sehr J. Error Detection in Laser Beam Melting Systems by High Resolution Imaging. 3. Aufl. München: Hanser; 2012.
- [21] Kruth J, Levy G, Klocke F, Childs THC. Consolidation phenomena in laser and powder-bed based layered manufacturing. *CIRP Ann - Manuf Technol* 2007;56:730–59. doi:10.1016/j.cirp.2007.10.004.
- [22] Berumen S, Bechmann F, Lindner S, Kruth J-P, Craeghs T. Quality control of laser- and powder bed-based Additive Manufacturing (AM) technologies. *Phys Procedia* 2010;5, Part B:617–22. doi:10.1016/j.phpro.2010.08.089.
- [23] Niendorf T, Leuders S, Riemer A, Brenne F, Tröster T, Richard H, et al. Functionally Graded Alloys Obtained by Additive Manufacturing. *Adv Eng Mater* 2014;16:857–61. doi:10.1002/adem.201300579.
- [24] Brackett D, Ashcroft I, Hague R. Topology optimization for additive manufacturing. *Proc. Solid Free. Fabr. Symp. Austin TX, 2011*, p. 348–62.
- [25] Vayre B, Vignat F, Villeneuve F. Designing for Additive Manufacturing. *Procedia CIRP* 2012;3:632–7. doi:10.1016/j.procir.2012.07.108.
- [26] Hauser C, Childs THC, Badrossamay M. Further Developments in Process Mapping and Modelling in Direct Metal Selective Laser Melting. 15th Solid Free Form Fabr Proc Eds Bourell RH Al Austin Tex August 2004:2–4.
- [27] Hodge NE, Ferencz RM, Solberg JM. Implementation of a thermomechanical model for the simulation of selective laser melting. *Comput Mech* 2014;54:33–51. doi:10.1007/s00466-014-1024-2.
- [28] Mohanty S, Tutum CC, Hattel JH. Cellular scanning strategy for selective laser melting: evolution of optimal grid-based scanning path and parametric approach to thermal homogeneity. In: Klotzbach U, Lu Y, Washio K, editors. *SPIE 8608 Laser-Based Micro-Nanopackaging Assem. VII*, vol. 86080M, 2013. doi:10.1117/12.2004256.
- [29] Kruth. *Powder Bed Fusion Additive Manufacturing* 2013.
- [30] Römer G, Mejer J, Aarts R. Multivariable control of laser alloying of Ti6Al4V. *Proc ICALEO* 1999;6: sensing and Monitoring.
- [31] Fathi A, Khajepour A, Toyserkani E, Durali M. Clad height control in laser solid freeform fabrication using a feedforward PID controller. *Int J Adv Manuf Technol* 2007;35:280–92. doi:DOI: 10.1007/s00170-006-0721-1.
- [32] Heralić A, Christiansson A-K, Lennartson B. Height control of laser metal-wire deposition based on iterative learning control and 3D scanning. *Opt Lasers Eng* 2012;50:1230–41. doi:10.1016/j.optlaseng.2012.03.016.
- [33] Salehi D, Brandt M. Melt pool temperature control using LabVIEW in Nd:YAG laser blown powder cladding process. *Int J Adv Manuf Technol* 2006;29:273–8. doi:10.1007/s00170-005-2514-3.
- [34] Devesse W, De Baere D, Guillaume P. Design of a Model-based Controller with Temperature Feedback for Laser Cladding. *Phys Procedia* 2014;56:211–9. doi:10.1016/j.phpro.2014.08.165.

- [35] Miyagi M, Tsukamoto T, Kawanaka H. Adaptive shape control of laser-deposited metal structures by adjusting weld pool size. *J Laser Appl* 2014;26:032003. doi:10.2351/1.4869499.
- [36] Song L, Bagavath-Singh V, Dutta B, Mazumder J. Control of melt pool temperature and deposition height during direct metal deposition process. *Int J Adv Manuf Technol* 2012;58:247–56. doi:10.1007/s00170-011-3395-2.
- [37] Hu D, Kovacevic R. Sensing, modeling and control for laser-based additive manufacturing. *Int J Mach Tools Manuf* 2003;43:51–60.
- [38] Hu D, Mei H, Kovacevic R. Closed loop control of 3d laser cladding based on infrared sensing, Austin, TX: 2001, p. 129–37.
- [39] Smurov I, Doubenskaia M, Zaitsev A. Comprehensive analysis of laser cladding by means of optical diagnostics and numerical simulation. *Surf Coat Technol* 2013;220:112–21. doi:10.1016/j.surfcoat.2012.10.053.
- [40] Pedersen DB, De Chiffre L, Hansen HN. *Additive Manufacturing: Multi Material Processing and Part Quality Control* 2013.
- [41] Yasa E, Deckers J, Craeghs T, Badrossamay M, Kruth J-P. Investigation on occurrence of elevated edges in Selective Laser Melting. *Solid Free. Fabr. Proc.*, Austin, TX: 2008.
- [42] Meier H, Haberland C. Experimental studies on selective laser melting of metallic parts. *Mater Werkst* 2008;39:665–70.
- [43] Yadroitsev I, Smurov I. Selective laser melting technology: From the single laser melted track stability to 3D parts of complex shape. *Phys Procedia* 2010;5:551–60. doi:10.1016/j.phpro.2010.08.083.
- [44] Mercelis P, Kruth J-P. Residual stresses in selective laser sintering and selective laser melting. *Rapid Prototyp J* 2006;12:254–65. doi:10.1108/13552540610707013.
- [45] Parthasarathy J, Starly B, Ramana S, Christensenb A. Mechanical evaluation of porous titanium (Ti6Al4V) structures with electron beam melting (EBM). *J Mech Behavior Biomed Mater* 2010;3:249–259.
- [46] Leuders S, Thoene M, Niendorf T, Troester T, Richard H, Maier H. On the mechanical behaviour of titanium alloy TiAl6V4 manufactured by selective laser melting: Fatigue resistance and crack growth performance. *Int J Fatigue* 2013;48:300–7.