

## PNEUMATIC SYSTEM DESIGN FOR DIRECT WRITE 3D PRINTING

Noah Holzman, Lorraine Francis

Department of Chemical Engineering and Materials Science, University of Minnesota,  
Minneapolis, MN 55455

### Abstract

Direct write 3D printing methods are interesting due to the diverse palette of materials available for the process. In this work, a pneumatic system for direct write printing is built using off-the-shelf hardware and synchronized with an open-source firmware for motion control. The time to steady-state pressure of the system is found to be ~150 ms for the range of pressures tested; this delay can lead to defects on the start of a path. Proof of concept is established by printing with a high viscosity, room temperature curing silicone using a 410  $\mu\text{m}$  nozzle and 300  $\mu\text{m}$  layer height. Test prints show a high degree of dimensional accuracy and consistent layer height over 10s of layers.

### Introduction

Liquid deposition or extrusion, frequently referred to as direct writing or direct ink writing (DIW)<sup>1</sup>, is promising for 3D printing of materials such as biomaterials<sup>2</sup>, electronic materials<sup>3</sup>, elastomers<sup>4</sup> and food products<sup>5</sup>. Direct write printing grew from the ‘robocasting’ method, which was used to print colloidal ceramic slurries as early as 1998<sup>6</sup>. In the process, a force is applied to a viscous material in a reservoir such as a syringe, and the material extrudes out through a nozzle. The nozzle size may be varied depending on the desired resolution; lines as small as 30  $\mu\text{m}$  have been printed successfully<sup>7</sup>. Previous works have not included much detail on the machine design or have used commercial dispense systems. In this paper, the design and methods of interfacing motion control with the pneumatic system are described to make the process more accessible overall.

### Experimental Hardware

A modified H-style XY gantry, utilizing NEMA-23 stepper motors and lead-screw driven Z platen, is used as the mechanical basis for our printer, though any platform capable of three axis movement is also suitable. A RAMPS 1.4 board<sup>8</sup> is used as a peripheral breakout board from the Arduino ATmega 2560 motherboard. The stepper driver and carriers (TI DRV8825, Pololu Robotics and Electronics) are capable of 1/32 microstepping, and the XYZ axes have 135, 105 and 634- steps per millimeter, respectively. For printing, a 10 mL syringe (Nordson EFD, Inc) is used as the material reservoir and a tapered nozzle with orifice size of 410  $\mu\text{m}$  (Nordson EFD, Inc) is attached to the syringe. General Electric Silicone Glue (Momentive Performance Materials) is used as the printing ink.

The pneumatic system, as show in *Figure 1*, is built from a 3/2 solenoid (ARO P251SS-024-D, Grainger) triggered using a signal from the Arduino. All other components were

assembled using 6 mm OD pneumatic tubing rated at 145 psi with push-to-connect fittings. The pressure is tuned manually by using the dispense regulator.

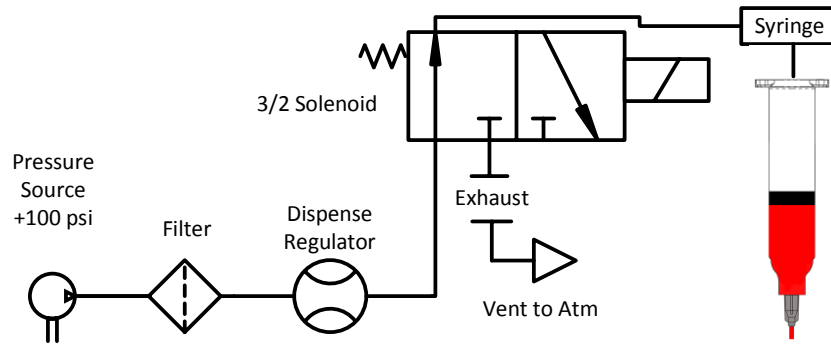

Figure 1: Pneumatic System shown in solenoid energized (dispensing) position

Since a 24V solenoid was chosen, it cannot be actuated directly from the RAMPS board. Rather, the interface circuit in Figure 2 is used. It is important to note that even if a 12V solenoid is used directly with the RAMPS board (such as the heated stage or fan pins), a reverse-biased diode is still necessary across the coil leads, since it is an inductive load.

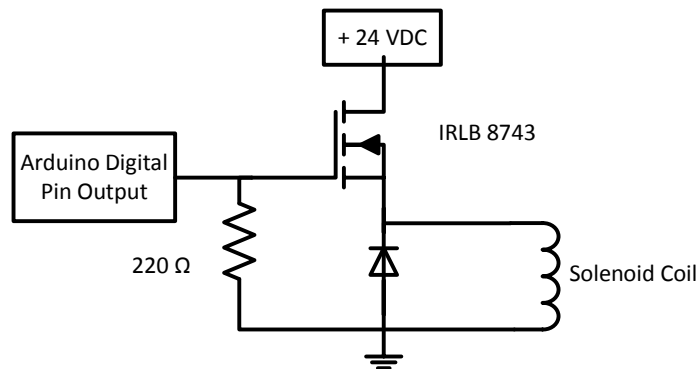

Figure 2: Interface circuit to actuate solenoid using Arduino low-voltage outputs

Pressure-time data is collected with a digital pressure sensor (QPSH-AN-42, Automation Direct) and an Arduino Mega 2560. A MATLAB script is triggered to begin collection by a digital output on the pressure sensor as shown in Figure 3. Data is stored in an array by reading a voltage across an analog input pin and a resistor to convert the standard 4-20 mA analog industrial control output into a 0-4.4 V signal.

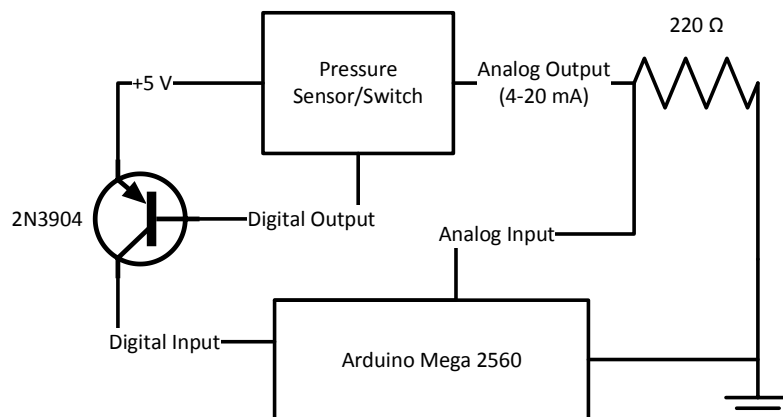

Figure 3: Pressure-time data collection circuit to trigger collection and log data

Volumetric flow calibration is performed by using a 5 second cycle and weighing the extruded material using an analytical balance.

### Experimental Software

Marlin<sup>9</sup> firmware is used on the host microcontroller, and Repetier/Slic3r<sup>10</sup> is used on a host desktop to generate and send g-code. Many varieties of firmware and software are available for 3D printing, but they are specifically optimized for mechanical extrusion of thermoplastic filaments. A post-slicing script is used to replace firmware retraction and priming commands (G10 and G11, respectively) with commands to actuate the solenoid through use of a digital pin on the Arduino (M42 Pnn Snn).

If using M42 commands in Marlin, it is important to note that they are unbuffered in the firmware, i.e. they are executed as soon as the controller reads them, not in sequence with the G-code. Thus, solenoid commands *must* be preceded by a M400 command for extrusion to be synchronized with motion. The pins for fan on/off commands (M106/M107) are buffered, so there is no need to use M400 if the fan pins are used.

### Results

Pressure-time data for a 500 ms dispense cycle in Figure 4 shows the rate of pressure increase and decrease for a given target or set pressure. The time taken to reach the set pressure and thus steady volumetric flow rate is approximately 150 ms. One interesting feature is that the decrease for the 14.8 and 24.3 psi experiments does not match the 34.9 psi experiment. This is attributed to the timing of data collection and the response of the sensor, which misses points at the end of the two curves. Further optimization of the program is needed to capture these points.

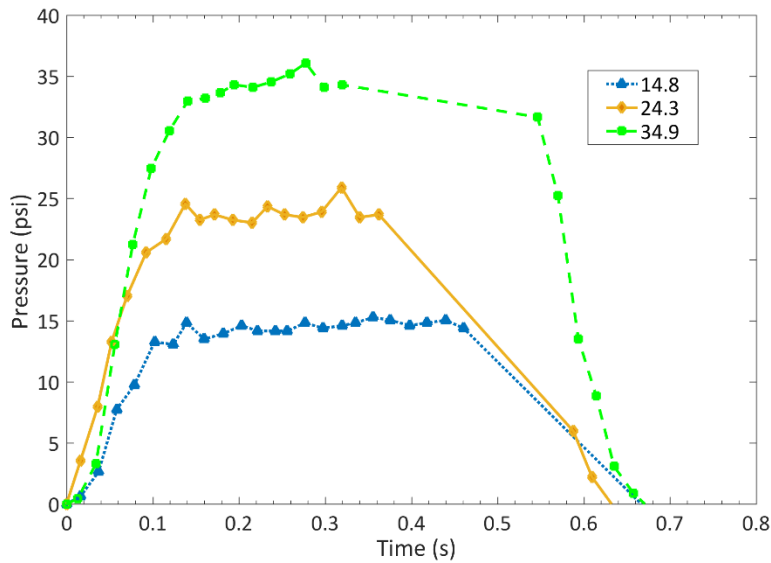

Figure 4: Pressure vs. time data for a 500 ms pulse at three different pressure setpoints.

Although the rate of pressure increase is fast, approximately 358 psi/s, a delay to allow material to begin flowing before the printhead moves is necessary to establish adhesion to the previous layer. Failure to incorporate a delay results in the defect shown in Figure 5.

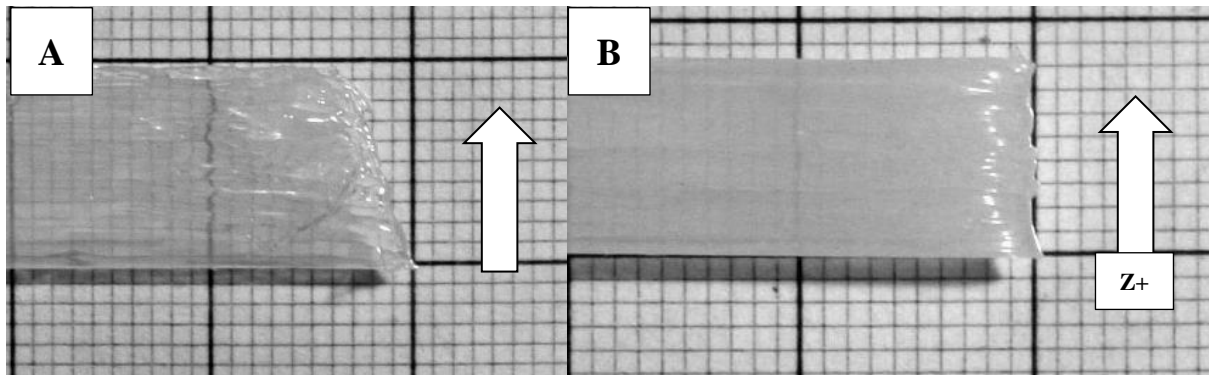

Figure 5: Effect of delay on printed single-width lines showing A) scalloped and poorly defined edge with no delay B) well-defined sharp edge with 150 ms delay

Test prints were performed after calibrating the material flow rate gravimetrically. A 410 micron nozzle, 300 micron slice height and 60 mm/s path velocity were used in all results shown. Figure 6 shows the cross-sections and side-views of printed lines.

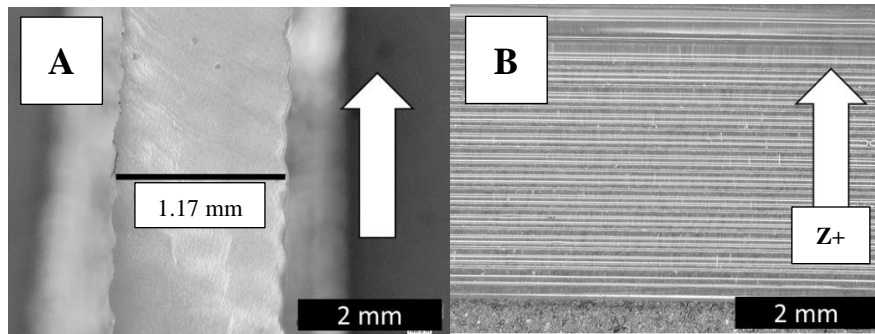

Figure 6: Verification of layer height and dimensional accuracy using A) cross-section of a 4-path width wide line and B) side view of layers. White arrows indicate Z+ build direction

The images show dimensional accuracy in the extruded cross section (1.17 mm actual vs. 1.20 mm nominal width). The difference can be accounted for by curing-induced shrinkage. The side-view images verify accuracy of the layer height and consistency over 10s of layers.

Future iterations of this device could be used for multi-material printing simply by replacing the 3/2 solenoid with a 5/3 solenoid and modifying the tool change commands to actuate the solenoid to select between material cartridges. Another useful feature would be incorporating an electrically operated precision regulator to allow pressure control from the firmware g-code interpreter or host computer.

### References

1. Truby, R. L. & Lewis, J. A. Printing soft matter in three dimensions. *Nature* **540**, 371–378 (2016).
2. Mannoor, M. S. *et al.* 3D printed bionic ears. *Nano Lett.* **13**, 2634–2639 (2013).
3. Frutiger, A. *et al.* Capacitive soft strain sensors via multicore-shell fiber printing. *Adv. Mater.* **27**, 2440–2446 (2015).
4. Roh, S., Parekh, D. P., Bharti, B., Stoyanov, S. D. & Velev, O. D. 3D Printing by Multiphase Silicone/Water Capillary Inks. *Adv. Mater.* **1701554**, 1701554 (2017).
5. Periard, D., Schaal, N., Schaal, M., Malone, E. & Lipson, H. Printing Food. *Proc. 18th Solid Free. Fabr. Symp.* 564–574 (2007). doi:10.1007/s00216-007-1293-0
6. Cesarano, J., Segalman, R. & Calvert, P. Robocasting provides mold-less fabrication from slurry. *Ceram. Ind.* **148**, 94 (1998).
7. Adams, J. J. *et al.* Conformal printing of electrically small antennas on three-dimensional surfaces. *Adv. Mater.* **23**, 1335–1340 (2011).
8. Russell, J. (Ultimaker). Ramps 1.4 Board. Available at: <http://reprap.org/wiki/Ramps>. (Accessed: 8th May 2017)
9. Lahtine, S. Marlin 3D Printer Firmware. (2017).
10. Ranellucci, A. Slic3r. (2016). Available at: <http://slic3r.org/about>. (Accessed: 18th January 2016)